

copyrighted 1960 by Allied Radio Corp/printed in U.S.A.

BILL FRANKLAND
RETURN



R-55 5-BAND SHORTWAVE RECEIVER 83 YU 935

ASSEMBLY MANUAL

knight-kit®

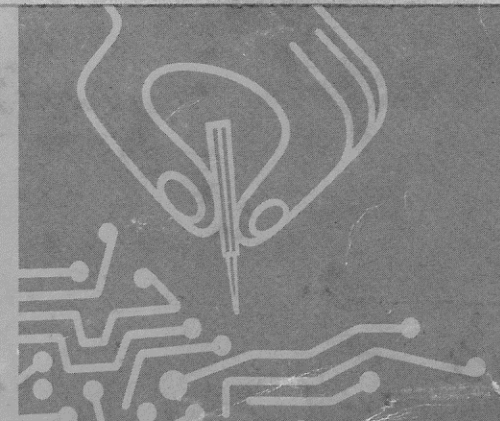

MODEL R-55 SHORTWAVE RECEIVER



1

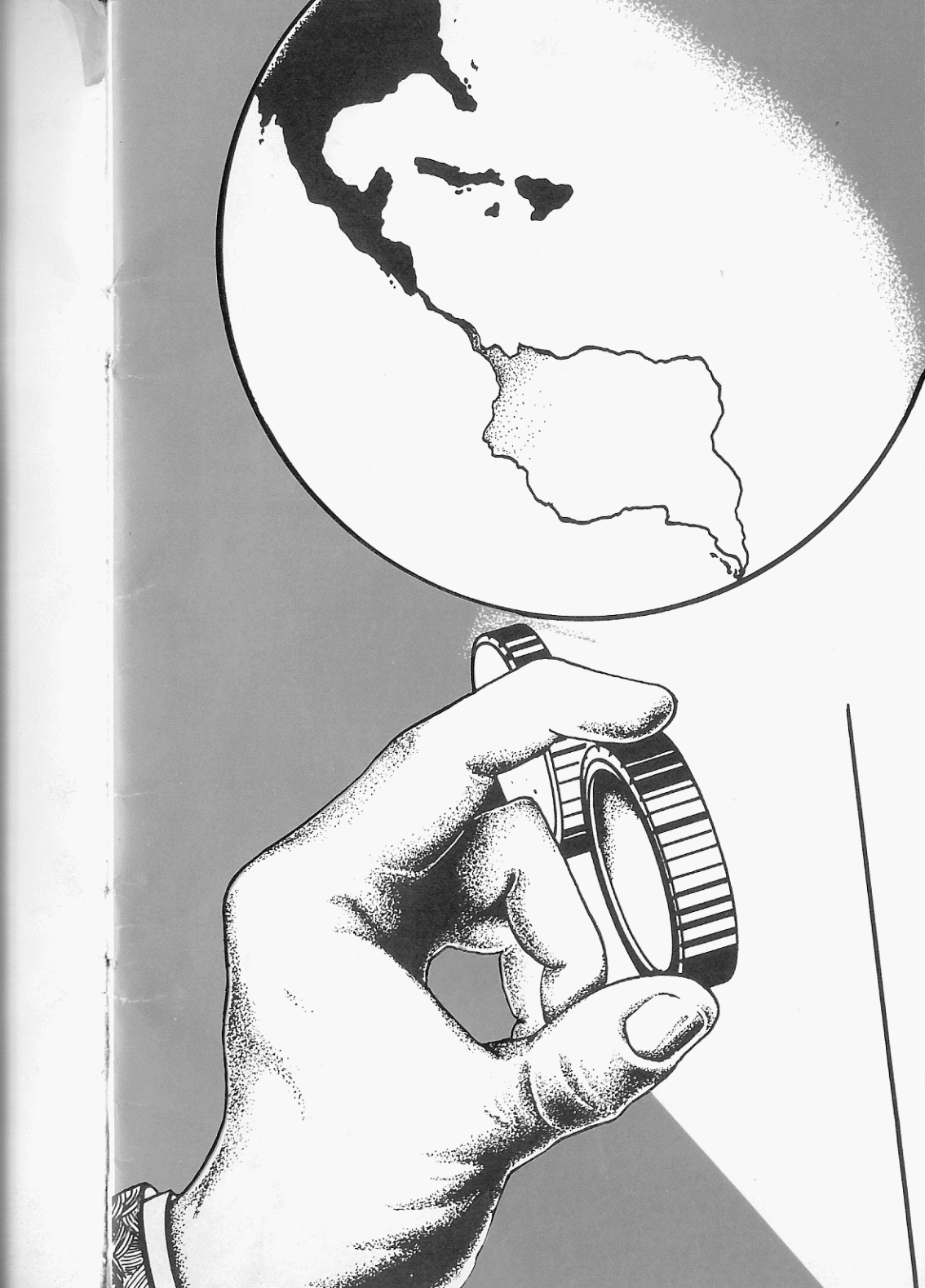

The new Knight-Kit R-55 is an outstanding general coverage communications receiver. Its up-to-date circuitry makes it an excellent choice for the newcomers to ham radio, shortwave fans, and technician licensees.

Tuning range is from 530 Kc to 36 mc with a separate range for the 6-meter Amateur band. All amateur bands from 80 to 6 meters have electrical bandspread individually calibrated to read frequency directly in megacycles.

Deluxe features include—2 IF stages for high sensitivity and good selectivity, 1650 Kc IF provides good image rejection, AVC, an effective noise limiter, adjustable BFO for CW and SSB reception, antenna trimmer, flywheel tuning and a handy phone jack.

Whether you're a beginning Ham or a shortwave listening fan—the Knight-Kit R-55 will place a world of exciting shortwave listening at your finger tips.



UNPACKING

- If you are not familiar with electronic parts, we suggest that you check each part against the parts list in the rear of the manual. If you are unable to identify some of the parts, find their pictures on the wiring illustrations or on the parts identification chart. As you check off the parts, assort them so they are readily available. You may find it advantageous to sort the hardware (screws, nuts, lock-washers, etc.) into suitable containers. This step will acquaint you with the various parts and thus simplify building.

HELPFUL CONSTRUCTION HINTS

This book uses some symbols to give the value of the parts. “ Ω ” means ohm, “K” means one thousand ohms, “meg” means one million ohms, μf means microfarad and $\mu\mu\text{f}$ means micromicrofarad. Capacitor markings may be μf or MF for microfarad; $\mu\mu\text{f}$ or MMF for micromicrofarad.

Several types of wire are supplied. It is important to use the wire called for in the building step.

Insulated solid wire, identified by color, has been cut to length and pre-stripped for your convenience. Use only the color given in the step.

The construction of this kit will require the use of a soldering iron, rated at about 100 watts, a pair of long-nose pliers, a pair of diagonal cutters and a screwdriver.

Follow the step-by-step instructions exactly. DO NOT ATTEMPT TO WIRE THIS KIT FROM THE PICTORIALS OR SCHEMATIC DIAGRAM ALONE because a definite wiring sequence must be followed. Occasionally, several parts are mounted with the same hardware, so BE SURE TO READ THE ENTIRE STEP. Check off each step after you have completed it.

The leads from electrical components must be held in place by good mechanical connections. A lead held in place by solder alone is a potential source of trouble.

To make a good mechanical connection, simply insert the end of the lead through the hole in the terminal; wrap the lead around the terminal and cut off the excess wire. Clamp the connection with your long-nose pliers. Figure 1 illustrates a connection that has been properly made.

Flexible tubing is used to cover bare wire or leads where there is a chance they may touch other bare wires or the chassis. BARE WIRES AND BARE LEADS NOT CONNECTED TO THE SAME TERMINAL MUST NOT ACCIDENTALLY TOUCH EACH OTHER OR THE CHASSIS.

HOW TO CARE FOR YOUR SOLDERING IRON

Before you start to solder, carefully clean the tip of your soldering iron with a fine file, or with steel wool, until the bright metal surface of the tip is exposed. Heat the iron; then cover (tin) the tip with a thin layer of ROSIN CORE SOLDER. While the iron is hot, remove excess solder from the tip by wiping with a clean cloth.

When the tip of the iron becomes covered with a dull, oxide film, wipe the tip with a clean cloth, and re-tin the iron.

To transfer the full heat of the iron, hold its greatest tip surface to the connection.

Never use the iron like a brush—soldering is not a paste-spreading operation.



THIS KIT MUST BE PROPERLY SOLDERED!

WITHOUT GOOD SOLDERING, AN ELECTRONIC UNIT WILL NOT WORK . . . just as a suit of clothing will fall apart if the stitches are loose . . . no matter how excellent the material.

USE ENOUGH HEAT

This is the main idea of good soldering. The purpose of soldering is to join metal parts, making an UNBROKEN metal path over which electricity can travel. To do this you must apply enough heat to the metal surfaces to make the solder spread freely on them, until the contour (shape) of the connection shows under the solder. If the solder barely melts and forms a rounded ball, *you are not using enough heat*. If you do not use enough heat, there may be no electrical connection, although it appears soldered.

HERE'S HOW TO DO IT . . .

1. Join bare metal to bare metal. Insulation must be removed.
2. Coat the tip of a hot iron with solder.
3. FIRMLY PRESS THE FLAT SIDE OF THE TIP OF A HOT IRON FLAT against the parts to be soldered together. Keep it there while you apply the solder BETWEEN THE IRON TIP AND THE METAL TO BE SOLDERED. Use only enough solder for it to flow over ALL the surfaces of the connection. Remove the iron.
4. DO NOT MOVE PARTS UNTIL THE SOLDER HARDENS. If you accidentally move the wires as the solder is hardening, apply your iron and reheat.

Compare your soldering with the pictures on this page. You have a good connection if your solder has flowed over all surfaces to be connected, following the shape of the surfaces. It should appear smooth and bright.

YOU HAVE NOT USED ENOUGH HEAT: If your connection is rough and flaky-looking, or if the solder has formed a round ball instead of spreading.

The difference between good soldering (enough heat) and poor soldering (not enough heat,) is just a few extra seconds with a hot iron FIRMLY applied. Remember, larger metal surfaces take a longer time to heat.

USE A 100-WATT IRON

A 100-watt soldering iron with a clean, chisel-shaped tip will supply the right amount of heat when used correctly. Notice how the iron is held in the picture. Heat the iron for 10 minutes before you start soldering. Keep the tip brightly coated with solder. When necessary, wipe the hot tip clean with a cloth. (If you use a soldering gun, be sure the tip reaches full heat before you solder.)

USE ONLY ROSIN CORE SOLDER

We supply the right kind of solder (*rosin core solder*). Do not use any other kind of solder! USE OF ACID CORE SOLDER, PASTE, OR IRONS CLEANED ON A SAL AMMONIAC BLOCK WILL RUIN ANY ELECTRONIC UNIT AND WILL VOID THE GUARANTEE.

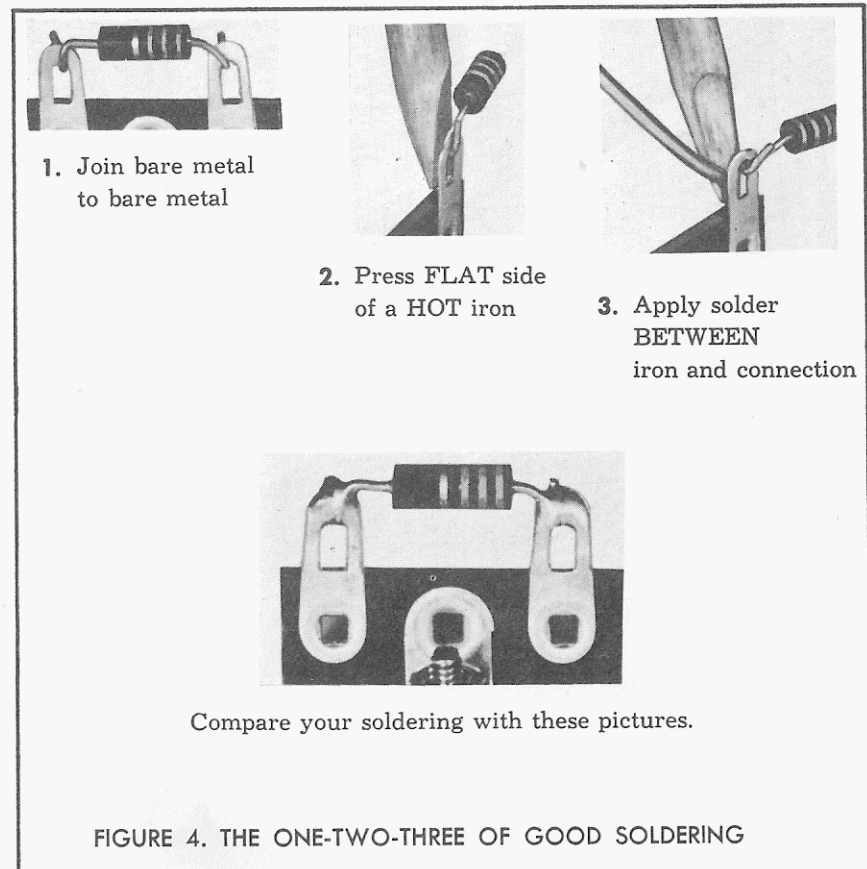
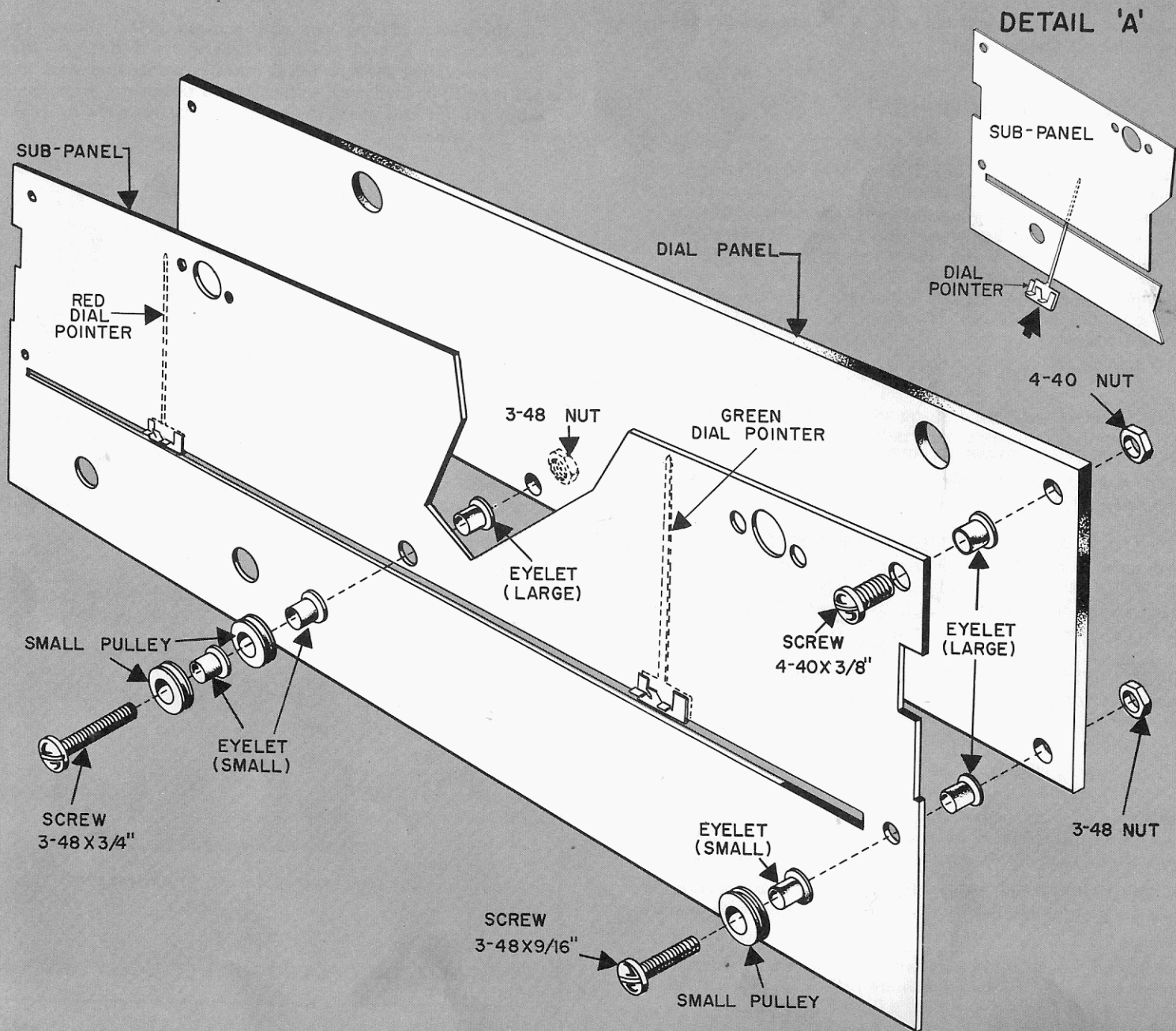



FIGURE 2





SEE FIGURE 2.

- The dial pointers and sub-panel (rectangular plate painted black). Position the panel, as shown. Insert the red dial pointer in the long slot of the panel about 3" from the left end, as shown in Figure 2, detail A. Install the GREEN pointer in the same slot about 3" from the right end. **Be careful not to bend the pointers.**
- Two small pulley wheels, two small (diameter) eyelets, and a 3-48 x 1/4" screw. Place a pulley wheel over each of the two eyelets. Place these two assemblies over the 3-48 screw so the shoulders on the eyelets are toward the end of the screw.
- Plexiglass dial panel. Remove the protective paper covering from the front of the dial panel.
- Sub-panel, large (diameter) eyelet and dial panel. Position the sub-panel as shown. Insert the screw with the two pulley wheels attached through the hole in the center of the panel. Place a large eyelet over the protruding end of this screw so the shoulder of the eyelet is toward the end of the screw. With the etched side of the dial panel facing the pointer side of the sub-panel, line up the mounting holes in both parts. Being careful not to disturb the dial pointers, place the dial panel over the screw assembly and loosely fasten with a 3-48 nut. Make sure the pulley wheels are between the dial pointers.
- Place a large eyelet between the dial panel and sub-panel, centering the eyelet over the lower right mounting hole with the shoulder toward the etched side of the dial panel.
- Small pulley wheel, small eyelet, 3-48 x 1/16" screw and nut. Place the eyelet and the pulley wheel over a 3-48 x 1/16" screw as you did previously. From the back of the sub-panel, insert this screw assembly through the mounting hole with the eyelet. Loosely fasten with a 3-48 nut.
- In a similar manner, fasten the lower left corner of the panels.
- Position a large eyelet over the top right mounting holes in the same manner as before. From the back of the sub-panel, insert a 4-40 x 3/8" screw through the holes and loosely fasten with a nut. Do not use the black screws. They are for mounting LS-1.
- In a similar manner, fasten the top left corner of the panels. **TIGHTEN ALL FIVE NUTS.**

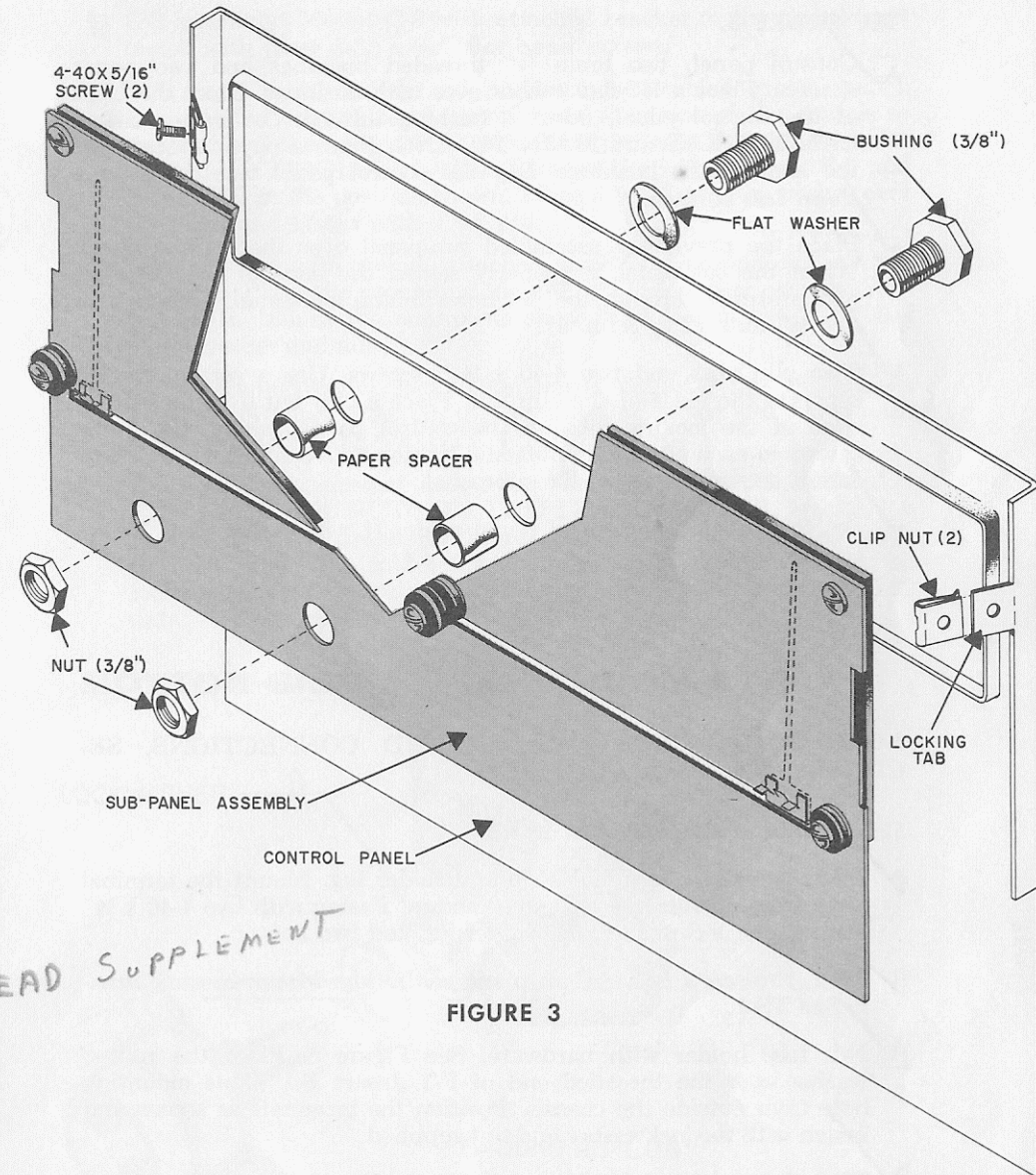
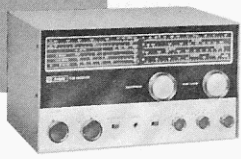

FIGURE 3

READ SUPPLEMENT



CONTROL PANEL ASSEMBLY

SEE FIGURE 3.

- Control panel, two brass $\frac{3}{8}$ " threaded bushings and two paper spacers. Place a $\frac{3}{8}$ " flat washer over both bushings. From the front of the control panel, insert a bushing through the holes marked BANDSPREAD and MAIN TUNING. Place a paper spacer over the ends of the bushings. Lay the control panel face down on a **clean soft surface**.
- Place the previously assembled sub-panel over the control panel. When the sub-panel is properly seated the ends of the bushings will protrude through the $\frac{3}{8}$ " holes in the sub-panel. Fasten with two $\frac{3}{8}$ " nuts (2 or 3 turns).
- Two clip nuts and two 4-40 x $\frac{5}{16}$ " screws. Use a screwdriver to separate the sides of the clip nut. Place a clip nut over the end of each of the locking tabs on the control panel. Insert one of the screws in each of the clip nuts and tighten with a screwdriver. These screws secure the top of the sub-panel.
- Set this assembled control panel aside. It will be mounted to the chassis later.

PARTS MOUNTING—CHASSIS BOTTOM

NOTE: TO ASSURE GOOD GROUND CONNECTIONS, SECURELY TIGHTEN ALL NUTS.

SEE FIGURE 4 ON SEPARATE SHEET.

- TS-1, two-screw terminal strip and solder lug. Mount the terminal strip from **outside** the chassis as shown. Fasten with two 4-40 x $\frac{3}{8}$ " screws, one lockwasher, one solder lug and two nuts.
- TS-2, two-screw terminal strip and solder lug. Mount in same manner as TS-1.
- F-1, fuse holder with hardware. See Figure 5. Place the rubber washer over the threaded end of F-1. Insert F-1 in its mounting hole from outside the chassis. Position the terminals as shown and fasten with the lockwasher and nut supplied.
- TS-3, 3-terminal strip. Mount to the inside of the chassis with a 4-40 x $\frac{3}{8}$ " screw, lockwasher and nut.

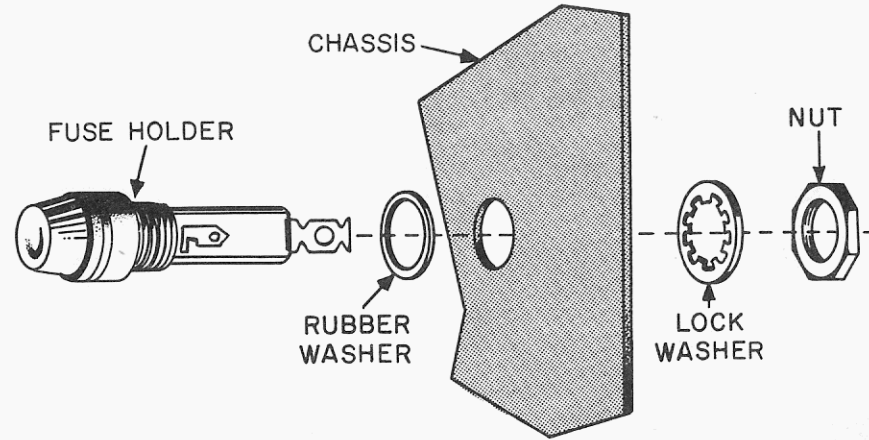

FIGURE 5

- Five $\frac{5}{16}$ " rubber grommets. Insert these grommets in the holes indicated.
- T-4, output transformer with four leads, TS-6, 3-terminal strip and solder lug. Bend the short bare lead up toward the top of T-4. Mount T-4 to the **top** of the chassis and feed the colored leads through the grommets indicated. See Figure 15. The solder lug and TS-6 are mounted with the same hardware. Mount the solder lug to the **top** of the chassis and TS-6 to the **bottom**. Fasten with two 4-40 x $\frac{3}{8}$ " screws, lockwashers and nuts.

NOTE: All parts are mounted to the inside of the chassis unless otherwise stated.

- 7-pin wafer tube socket for V-6 (without shield clip), solder lug and TS-4, 4-terminal strip. Mount the tube socket with its **keyway** as shown. The keyway is the wide space between two of the pins. Mount TS-4 between the chassis and the socket. Similarly mount the solder lug. Fasten with two 4-40 x $\frac{3}{8}$ " screws, lockwashers and nuts.

NOTE: Any terminal strips or solder lugs to be mounted to the inside of the chassis along with a tube socket will be mounted between the chassis and tube socket.



- ✓ 7-pin wafer tube socket for V-2, and one solder lug. See Figure 15. Mount the solder lug to the **top** of the chassis. Fasten with two 4-40 x $\frac{3}{8}$ " screws, one lockwasher and two nuts. The screw nearer the keyway does not receive a lockwasher.
- ✓ 7-pin wafer tube socket for V-4 and TS-5, 4-terminal strip. Position the parts as shown and fasten with two 4-40 x $\frac{3}{8}$ " screws, one lockwasher and two nuts. The screw nearer the keyway does not receive a lockwasher.
- ✓ 9-pin wafer tube socket for V-3 and TS-7, 6-terminal strip. Similarly mount this tube socket and terminal strip. Fasten with two 4-40 x $\frac{3}{8}$ " screws, one lockwasher and two nuts. The screw nearer the keyway does not receive a lockwasher.
- ✓ 9-pin wafer tube socket for V-5, and TS-8, 6-terminal strip. Similarly mount this tube socket and terminal strip. Fasten with two 4-40 x $\frac{3}{8}$ " screws, one lockwasher and two nuts. The screw nearer the keyway does not receive a lockwasher.
- ✓ 7-pin molded tube socket for V-1, shield saddle and solder lug. Position the shield saddle over the mounting holes at the **top** of the chassis. Mount the tube socket and solder lug to the bottom of the chassis and fasten with two 3-48 x $\frac{1}{4}$ " screws, nuts and two #4 lockwashers.
- ✓ TS-9, 2-terminal strip and solder lug. Fasten with a 4-40 x $\frac{3}{8}$ " screw and nut.
- ✓ Mounting plate for C-36. Mount the plate as shown, and fasten with two 4-40 x $\frac{3}{8}$ " screws, lockwashers and nuts.
- ✓ S-4 slide switch and solder lug. Mount S-4 so the off-set terminal is to the left of the center terminal. Fasten with two 6-32 x $\frac{1}{16}$ " **flat head** screws, one lockwasher, solder lug and two nuts.
- ✓ S-3 slide switch. Mount S-3 so the off-set terminal is to the right of the center terminal. Fasten with two 6-32 x $\frac{1}{16}$ " **flat head** screws, lockwashers and nuts.
- ✓ C-14, variable capacitor with two rotating plates. Before mounting, close the plates by rotating the shaft. Mount exactly as shown. Fasten with three 6-32 x $\frac{1}{16}$ " **flat head** screws, using the three threaded holes in the capacitor.
- ✓ C-3, variable capacitor with six rotating plates and L shaped bracket. Close the plates of the capacitor. Fasten the bracket to the back of C-3 with three 6-32 x $\frac{1}{16}$ " round head screws.
- ✓ Solder lug. Fasten the solder lug to the bracket attached to C-3 with a 4-40 x $\frac{3}{8}$ " screw and nut.

- ✓ C-3 assembly. Mount C-3 with attached bracket to the chassis and fasten with three 6-32 x $\frac{1}{16}$ " **flat head** screws.
- ✓ S-2, single wafer switch and previously assembled control panel. Position the control panel assembly to the front of the chassis so the shafts of the two variable capacitors protrude through the holes marked ANTENNA and BFO. Remove the $\frac{3}{8}$ " nut from S-2 and mount S-2 in the position shown. Place a $\frac{3}{8}$ " flat metal washer over the shaft and fasten with a $\frac{3}{8}$ " nut.
- ✓ R-30 control with switch attached, and long grounding lug. See Figure 6. Place the grounding lug and $\frac{3}{8}$ " lockwasher over the control shaft. Mount the control as shown and fasten with a $\frac{3}{8}$ " flat metal washer and nut.
- ✓ J-1, 3-terminal phone jack. Temporarily mount J-1 to the chassis and control panel. Position the terminals as shown and fasten with a $\frac{3}{8}$ " nut. **DO NOT TIGHTEN THE NUT.**
- ✓ T-5, power transformer and #8 solder lug. **DO NOT REMOVE THE FOUR 8-32 NUTS ON THE TRANSFORMER.** Mount T-5 to the top of the chassis so the red and yellow/red leads are closer to TS-4. Place the solder lug over the screw shown. Place a #8 lockwasher over the remaining three screws. Fasten with four 8-32 nuts.

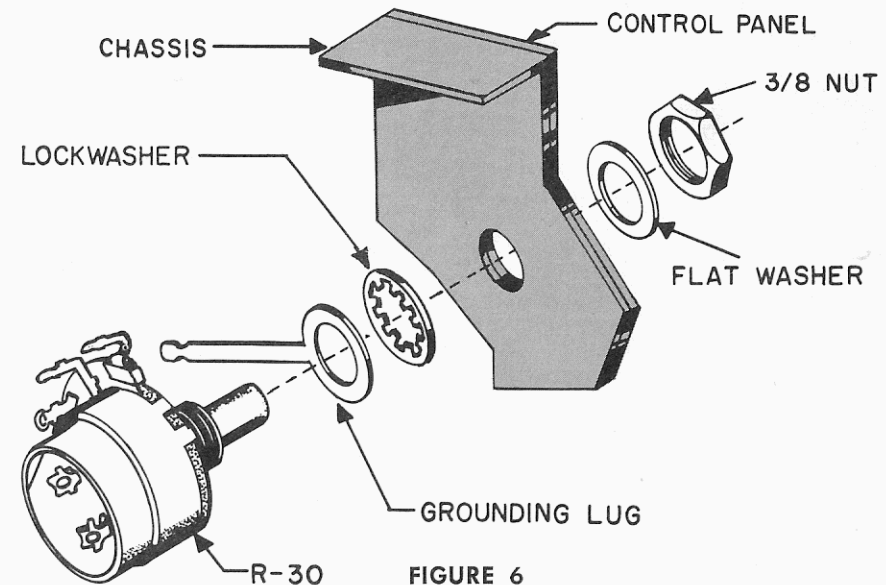

FIGURE 6



IMPORTANT INSTRUCTIONS

CONNECT means: Connect the wire or lead to the given point. Make a firm mechanical connection **BUT DO NOT SOLDER AT THIS TIME**. Later another wire (s) will be connected to this point.

SOLDER means: Connect the wire or lead to the given point and then **SOLDER THE CONNECTION AND ALL WIRES IN IT**. If there is more than one wire in the connection, the number of wires will be stated. For example, if the building step tells you to “solder the shield wire to the solder lug (4 wires),” it means there should be four wires connected to that solder lug when you solder it. **If you do not have the stated number of wires you have made an error. Go back and check your work.**

7 leads of T-5:

- Connect one of the green leads to the solder lug attached to T-5.
- Connect the remaining green lead to terminal 1 of TS-4.
- Connect one of the black leads to terminal 4 of TS-4.
- Connect the remaining black lead to terminal 2 of TS-4.
- Solder one of the red leads to pin 1 of V-6.
- Solder the remaining red lead to pin 6 of V-6.
- Solder the yellow/red lead to terminal 1 of TS-2.
- Red/white/black wire and green lead of T-4. Feed one end of the red/white/black wire through the grommet that has the green lead until the end of the green lead is even with the end of the red/white/black wire. Twist the wires together.
- Connect the green lead to terminal 1 of J-1.
- Solder the end of the red/white/black wire to terminal 2 of J-1.
- Connect the blue lead of T-4 to pin 9 of V-5.
- Connect the red lead of T-4 to terminal 2 of TS-7.

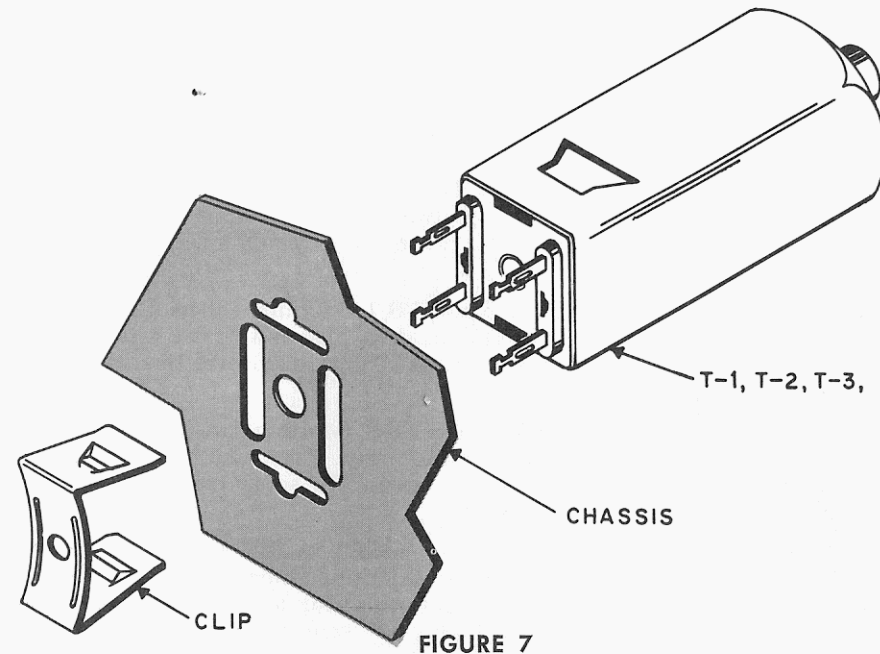

FIGURE 7

- T-1, IF transformer in metal can, (T-1 stamped on can). Mount the transformer to the **top** of the chassis with the **color dot** in the position shown. See Figure 7. Fasten with a U shaped metal clip. Insert the ends of the clip in the two slots from the bottom of the chassis. While holding the coil in position, push the clamp onto the can until both ends of the clamp snap into position on the sides of the can.
- T-2, (T-2 stamped on can). Similarly mount T-2. Note the position of the color dot.
- T-3, (T-3 stamped on can). Similarly mount T-3. Note the position of the color dot.
- L-11, coil in metal can. Similarly mount L-11. Note position of color dot.
- C-36, 40-40-40-40 μ f electrolytic capacitor in can. Mount to the **top** of the chassis as shown. Twist the mounting tabs with your long-nose pliers to hold in place.



SEE FIGURE 8 ON SEPARATE SHEET.

- ✓ Orange wire. Solder one end to pin 7 of V-6. Connect the other end to terminal 1 of C-36.
- ✓ Red wire. Solder one end to terminal 1 of TS-4 (2 wires). Connect the other end to pin 3 of V-6.
- ✓ 1 1/4" heavy bare wire. Solder one end to pin 4 of V-6. Solder the other end to the solder lug attached to V-6.
- ✓ 3/4" thin bare wire. Connect one end to the center pin of V-2. Connect the other end to pin 4.
- ✓ 3/4" thin bare wire. Solder one end to the center pin of V-2 (2 wires). Connect the other end to pin 7 of V-2.
- ✓ Green wire. Connect one end to pin 3 of V-6. Connect the other end to the bottom hole of pin 3 of V-2.
- ✓ Blue wire. Connect one end to the bottom hole of pin 3 of V-2. Solder the other end to pin 4 of V-1.
- ✓ Green wire. Connect one end to pin 3 of V-2. Connect the other end to pin 5 of V-5.
- ✓ 1 1/4" heavy bare wire and 1 1/4" ~~black~~ ^{YELLOW} tubing. Place the tubing over the wire. Solder one end of the wire to pin 1 of V-2. Solder the other end to terminal 1 of T-1.
- ✓ 1 1/2" thin bare wire. Solder one end to pin 3 of V-1. Solder the other end to the solder lug attached to TS-9.
- ✓ 1 1/2" heavy bare wire. Solder one end to terminal 2 of S-3. Connect the other end to terminal 1 of TS-9.
- ✓ Green wire. Solder one end to terminal 1 of S-3. Connect the other end to pin 1 of V-5.
- ✓ 1 3/4" heavy bare wire. Solder one end to terminal 1 of L-11. Connect the other end to pin 2 of V-5.
- ✓ 1" thin bare wire. Connect one end to the center pin of V-5. Connect the other end to pin 4 of V-5.
- ✓ 1" thin bare wire. Connect one end to the center pin of V-3. Solder the other end to pin 4.
- ✓ Yellow wire. Solder one end to pin 5 of V-5 (2 wires). Connect the other end to pin 5 of V-3.
- ✓ Red wire. Solder one end to pin 5 of V-3 (2 wires). Solder the other end to pin 3 of V-4.

- ✓ 4" heavy bare wire. Place a 3/4", 90° bend in one end of the wire. Place a 1/2", 90° bend in the other end. Solder the end with the 1/2" bend to terminal 4 of T-2. Connect the other end to pin 7 of V-3.
- ✓ 1" thin bare wire. Pass one end through the center pin of V-4 and solder to pin 4. Solder the other end to pin 1.

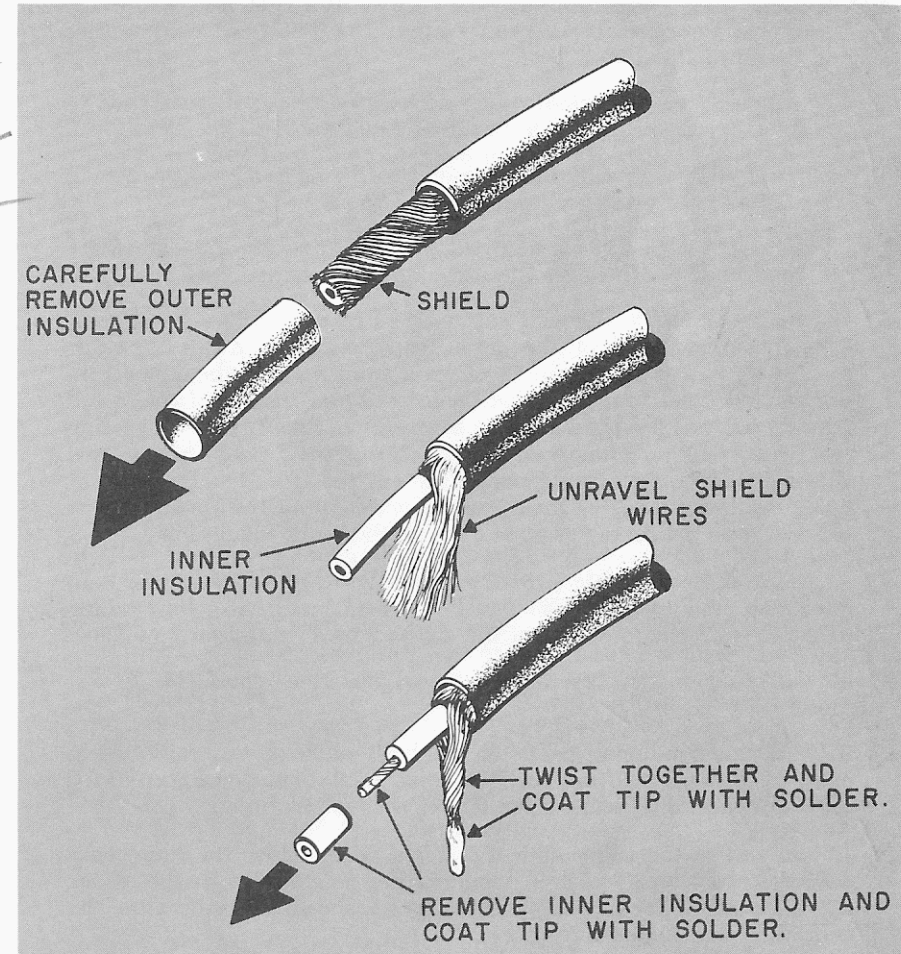

FIGURE 9



- 2ND NIGHT*
- ✓ Yellow wire. Connect one end to terminal 6 of TS-7. Connect the other end to terminal 6 of TS-8.
 - ✓ Violet wire. Connect one end to terminal 6 of TS-8. Solder the other end to terminal 5 of S-2.
 - ✓ Blue wire. Connect one end to terminal 3 of TS-8. Solder the other end to terminal 4 of S-2.
 - ✓ Blue wire. Connect one end to terminal 2 of TS-8. Solder the other end to terminal 2 of S-2.
 - ✓ 1½" heavy bare wire. Solder one end to the solder lug attached to TS-2. Solder the other end to terminal 2 of TS-2.
 - ✓ 1½" heavy bare wire. Solder one end to the solder lug attached to TS-1. Solder the other end to terminal 2 of TS-1.
 - ✓ 1" thin bare wire. Solder one end to the grounding lug (gnd lug) attached to R-30. Connect the other end to terminal 3 of R-30.
 - ✓ 5" single-conductor shielded cable. See Figure 9 for cable preparation. From one end of the cable, carefully strip away 1" outer insulation. Unwind the shield strands from around the inner conductor and twist them together. Lightly solder the tip of the shield wire to prevent the strands from unraveling. Remove ¼" insulation from the inner conductor and lightly coat the tip of the exposed wire with solder. From the other end of the cable, strip away 1" outer insulation and ¼" inner insulation. Remove the shield wire at this end by cutting the strands close to the outer insulation.
 - ✓ At the end of the cable **with** the shield wire, solder the inner conductor to pin 7 of V-3 (2 wires). Place a ½" length of yellow tubing over the shield wire. Connect the shield wire to terminal 3 of TS-7.
 - ✓ At the other end of the cable, connect the inner conductor to terminal 1 of TS-8.
 - ✓ 15½" single-conductor cable. From both ends of the cable, strip away 1" outer insulation and ¼" inner insulation. See Figure 9 for cable preparation. Remove the shield wire from one end.
 - ✓ At the end of the cable **with** the shield wire, solder the inner conductor to terminal 1 of S-4. Connect the shield wire to the solder lug attached to S-4. Route the cable as shown, making sure the cable is under the leads from T-4.
 - ✓ At the other end of the cable, connect the inner conductor to terminal 2 of V-4.
 - ✓ 7½" single-conductor cable. From both ends of the cable, strip away 1" outer insulation and ¼" inner insulation. Remove the shield wire from one end of the cable.
 - ✓ At the end of the cable **with** the shield wire, solder the inner conductor to terminal 2 of R-30. Connect the shield wire to terminal 3.
 - ✓ At the other end of the cable, solder the inner conductor to pin 2 of V-3.
 - ✓ Green wire. Solder one end to terminal 3 of C-36. Connect the other end to terminal 2 of TS-7.
 - ✓ 7" single-conductor shielded cable. Prepare this cable exactly as you did the 7½" cable.
 - ✓ At the end of the cable **without** the shield wire, solder the inner conductor to terminal 1 of R-30.
 - ✓ At the other end of the cable, solder the shield wire to terminal 2 of TS-6. Connect the inner conductor to terminal 3.
 - ✓ 14" two-conductor shielded cable. This cable is prepared in the same manner as the single conductor cable. From one end of the cable, strip away 1" outer insulation. Hold the inner conductors with your longnose pliers. Strip away ¼" insulation. Remove the shield wire at this end. From the other end of the cable, strip away 1½" outer insulation and ¼" inner insulation.
 - ✓ At the end of the cable **without** the shield wire, solder the red wire to terminal 2 of S-5. Solder the black wire to terminal 1.
 - ✓ At the other end of the cable, solder the black wire to terminal 2 of F-1. Connect the red wire to terminal 3 of TS-3. Place a 1¼" length of yellow tubing over the shield wire. Solder the shield wire to terminal 2 of TS-3.
 - ✓ 11" two-conductor shielded cable. From one end of the cable, strip away 1" outer insulation and ¼" inner insulation. From the other end of the cable, strip away 1½" outer insulation and ¼" inner insulation. Remove the shield wire from this end of the cable. Hold the wires with your longnose pliers when stripping the inner insulation.
 - ✓ At the end of the cable **without** the shield wire, solder the black wire to terminal 1 of F-1. Connect the red wire to terminal 1 of TS-3.
 - ✓ At the other end of the cable, solder the shield wire to the solder lug attached to T-5 (2 wires). Connect the red wire to terminal 4 of TS-4. Connect the black wire to terminal 2.

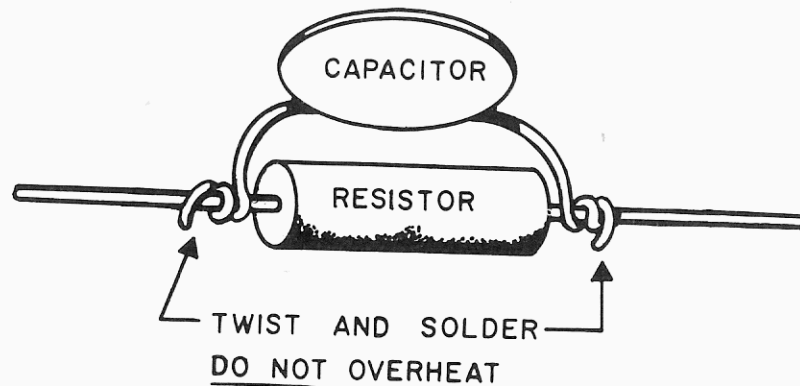

FIGURE 10

- R-1, 22K resistor (red, red, orange) and C-5, 20 $\mu\mu\text{f}$ disc capacitor. Wrap the leads of C-5 around the leads of R-1 as shown in Figure 10. Solder both leads of C-5 and cut the excess lengths.
- NOTE: WHEN CONNECTING RESISTORS AND CAPACITORS, MAKE LEAD LENGTHS AS SHORT AS POSSIBLE.**
- Connect one lead of the R-1 combination to the solder lug attached to V-1. Connect the other lead to pin 1 of V-1. It is important to keep leads short.
- R-7, 47K resistor (yellow, violet, orange) and C-15, 100 $\mu\mu\text{f}$, mica capacitor. Prepare this resistor and capacitor in the same manner as R-1 and C-5.
- Solder one lead of the R-7 combination to terminal 2 of V-5 (2 wires). Solder the other lead to terminal 4 (2 wires).
- C-4, 75 $\mu\mu\text{f}$ silver mica capacitor (rectangular shaped). Connect one lead to terminal 2 of TS-9. Solder the other lead to pin 1 of V-1 (2 wires).
- C-8, .001 μf disc capacitor. Connect one lead to pin 6 of V-1. Connect the other lead to the solder lug attached to V-1.
- C-9, .05 μf disc capacitor. Connect one lead to pin 7 of V-2. Connect the other lead to terminal 4 of T-1.
- C-10, .0047 μf disc capacitor (may be marked 4700 $\mu\mu\text{f}$). Solder one lead to the solder lug attached to V-1 (3 wires). Connect the other lead to terminal 2 of T-1.
- C-19, 150 $\mu\mu\text{f}$ disc capacitor. Connect one lead to pin 2 of V-2. Connect the other lead to pin 6.
- R-6, 22K resistor (red, red, orange) and two $\frac{3}{4}$ " lengths of black tubing. Cut each lead to 1". Place the tubing over both leads. Solder one lead to pin 6 of V-2 (2 wires). Connect the other lead to terminal 6 of TS-7.
- R-20, 1.3K resistor (brown, orange, red) and $\frac{1}{2}$ " length of black tubing. Cut each lead to $\frac{3}{4}$ ". Place the tubing over one of the leads. Connect this lead to terminal 6 of TS-7. Connect the other lead to terminal 1 of T-3.
- R-17, 1 meg resistor (brown, black, green) and two $\frac{1}{2}$ " lengths of black tubing. Cut each lead to $\frac{3}{4}$ ". Place the tubing over the leads. Connect one lead to terminal 5 of TS-7. Connect the other lead to terminal 3 of T-3.
- R-22, 47K resistor (yellow, violet, orange). Connect one lead to terminal 3 of T-3. Connect the other lead to terminal 1 of TS-5.
- C-28, .001 μf disc capacitor and two $\frac{3}{4}$ " lengths of black tubing. Cut each lead to 1". Place the tubing over the leads. Solder one lead to terminal 3 of T-3 (3 wires). Connect the other lead to terminal 3 of TS-5.
- R-29, 470K resistor (yellow, violet, yellow). Connect one lead to terminal 3 of TS-5. Connect the other lead to terminal 2.
- R-27, 470K resistor (yellow, violet, yellow). Connect one lead to terminal 4 of TS-5. Connect the other lead to terminal 5 of V-4.
- R-21, 2.2 meg resistor (red, red, green). Solder one lead to the center pin of V-4 (2 wires). Connect the other lead to terminal 2 of V-4.
- C-29, .01 μf disc capacitor. Connect one lead to pin 3 of V-3. Connect the other lead to pin 7 of V-5.
- R-23, 470K resistor (yellow, violet, yellow). Connect one lead to pin 7 of V-5. Connect the other lead to the center pin.
- R-33, 100 Ω 1 watt resistor (brown, black, brown). Solder one lead to terminal 2 of TS-7 (3 wires). Connect the other lead to terminal 6 of TS-8.

3RD NIGHT



SECOND WIRING—BOTTOM

SEE FIGURE 11 ON SEPARATE SHEET.

- L-12, choke coil. Mount to the inside of the chassis with the two leads toward the inside surface of the chassis. Fasten with two 4-40 x $\frac{3}{8}$ " screws, lockwashers and two nuts.
- Solder one of the black leads from L-12 to terminal 1 of C-36 (2 wires). Connect the other lead to terminal 4. (If leads are too long, cut to correct length.)
- Line cord. Feed the bare ends of the line cord through the grommet. Place a knot in the cord about 3" from the bare ends.
- Solder one of the wires to terminal 3 of TS-3 (2 wires). Solder the other wire to terminal 1 (2 wires).
- C-39, .0047 μf disc capacitor (may be marked 4700 $\mu\mu\text{f}$). Solder one lead to terminal 4 of TS-4 (3 wires). Connect the other lead to terminal 3.
- C-40, .0047 μf disc capacitor (may be marked 4700 $\mu\mu\text{f}$). Solder one lead to terminal 3 of TS-4 (2 wires). Solder the other lead to terminal 2 (3 wires).
- R-12, 100K resistor (brown, black, yellow) and a $\frac{3}{4}$ " length of black tubing. Cut each lead to 1". Place the tubing over one of the leads. Connect this lead to terminal 5 of TS-7. Connect the other lead to terminal 3 of T-2.
- R-11, 1.8K resistor (brown, gray, red) and two $\frac{3}{4}$ " lengths of black tubing. Place the tubing over the leads. Solder one lead to terminal 1 of T-2. Connect the other lead to terminal 6 of TS-7.
- C-20, 10 $\mu\mu\text{f}$ disc capacitor and $\frac{1}{2}$ " black tubing. Cut each lead to $\frac{3}{4}$ ". Place the tubing over one lead. Solder this lead to terminal 3 of T-2 (2 wires). Connect the other lead to pin 4 of V-2.
- C-37, .001 μf disc capacitor. Solder one lead to pin 4 of V-2 (3 wires). Solder the other lead to pin 3 (4 wires).
- $1\frac{1}{2}$ " heavy bare wire. Solder one end to terminal 2 of T-2. Solder the other end to pin 5 of V-2.
- C-11, .05 μf disc capacitor and R-5, 180 Ω resistor (brown, gray, brown). Wrap the leads of C-11 around R-5, as you did previously, and solder these connections.
- R-5 combination. Solder one lead to pin 7 of V-2 (3 wires). Solder the other lead to pin 2 of V-2 (2 wires).
- R-4, 100K resistor (brown, black, yellow) and $\frac{1}{2}$ " length of black tubing. Place the tubing over one lead. Connect this lead to terminal 2 of TS-8. Solder the other lead to terminal 2 of T-1 (2 wires).
- R-31, 33 Ω resistor (orange, orange, black). Solder one of the leads to terminal 3 of J-1. Solder the other lead to terminal 1 (2 wires).
- 2" heavy bare wire. Connect one end to the terminal on C-14. Connect the other end to terminal 2 of L-11.
- C-13, 6.2 $\mu\mu\text{f}$ capacitor (blue, red, white, gold). Solder one lead to the terminal on C-14 (2 wires). Connect the other lead to terminal 1 of S-2.
- 3" heavy bare wire. Solder one end to terminal 1 of S-2 (2 wires). Solder the other end to terminal 3 of R-30 (~~2 wires~~). **3 WIRES**
- R-13, 4.7 meg resistor (yellow, violet, green) and two $\frac{1}{2}$ " lengths of black tubing. Cut each lead to $\frac{3}{4}$ ". Place the tubing over the leads. Solder one lead to terminal 1 of TS-8 (2 wires). Connect the other lead to terminal 2 of L-11.
- C-18, 1000 $\mu\mu\text{f}$ mica capacitor and two $\frac{1}{2}$ " lengths of black tubing. Cut each lead to $\frac{3}{4}$ ". Place the tubing over each lead. Solder one lead to terminal 2 of L-11 (3 wires). Connect the other lead to pin 3 of V-5.
- R-10, 220K resistor (red, red, yellow) and two $\frac{1}{2}$ " lengths of black tubing. Cut each lead to $\frac{3}{4}$ ". Place the tubing over the leads. Solder one lead to pin 3 of V-5 (2 wires). Connect the other lead to terminal 5 of TS-8.
- Blue wire. Solder one end to terminal 2 of C-36. Connect the other end to pin 8 of V-5.
- R-25, 10K resistor (brown, black, orange), 1 watt. Connect one lead to pin 8 of V-5. Connect the other lead to terminal 1 of TS-7.
- C-31, 50 μf electrolytic capacitor and R-24, 150 Ω resistor (brown, green, brown). Wrap the leads of R-24 around the leads of C-31 and solder. Remove the excess lead lengths from R-24.
- C-31 combination. Connect the **plus (+)** lead to pin 6 of V-5. Connect the other lead to the center pin.
- C-30, 470 $\mu\mu\text{f}$ disc capacitor. Solder one lead to pin 6 of V-5 (2 wires). Solder the other lead to pin 7 (3 wires).
- R-8, 39K resistor (orange, white, orange). Connect one lead to terminal 4 of TS-8. Connect the other lead to terminal 5.
- R-9, 100K resistor (brown, black, yellow). Connect one lead to terminal 6 of TS-8. Connect the other lead to terminal 5.

REA
SUPP



- ✓ 1" thin bare wire. Solder one end to terminal 6 of TS-8 (5 wires). Connect the other end to terminal 1 of TS-7.
- ✓ Green wire. Connect one end to terminal 2 of TS-8. Connect the other end to terminal 4 of TS-7.
- ✓ C-12, .02 μf disc capacitor. Solder one lead to terminal 2 of TS-8 (4 wires). Connect the other lead to terminal 4.
- ✓ C-42, .01 μf disc capacitor. Connect one lead to terminal 3 of TS-7. Connect the other lead to terminal 5.
- ✓ C-25, 50 μf electrolytic capacitor and R-15, 2.7K resistor (red, violet, red). Wrap the leads of R-15 around the leads of C-25 and solder. Remove the excess lead lengths from R-15.
- ✓ C-25 combination. Solder the (+) PLUS lead to pin 1 of V-3. Connect the other lead to terminal 3 of TS-7.
- ✓ Red wire. Solder one end to pin 9 of V-3. Solder the other end to pin 2 of T-3.
- ✓ C-24, 470 $\mu\mu\text{f}$ disc capacitor. Connect one lead to pin 6 of V-3. Connect the other lead to pin 8.
- ✓ C-27, .01 μf disc capacitor and two 1" lengths of black tubing. Cut each lead to 1 1/4". Place the tubing over the leads. Solder one lead to terminal 1 of T-3 (2 wires). Connect the other lead to pin 6 of V-3.
- ✓ R-26, 100K resistor (brown, black, yellow). Connect one lead to terminal 1 of TS-5. Connect the other lead to terminal 2.
- ✓ C-33, .01 μf disc capacitor. Connect one lead to terminal 1 of TS-5. Solder the other lead to terminal 2 of V-4 (3 wires).
- ✓ C-32, 100 $\mu\mu\text{f}$ disc capacitor. Solder one lead to terminal 1 of TS-5 (4 wires). Connect the other lead to terminal 3.
- ✓ C-34, .01 μf disc capacitor. Solder one lead to terminal 3 of TS-5 (4 wires). Connect the other lead to terminal 4.
- ✓ R-28, 470K resistor (yellow, violet, yellow). Solder one lead to terminal 2 of TS-5 (3 wires). Solder the other lead to terminal 4 (3 wires).
- ✓ 3 1/2" heavy bare wire. Place a 3/4", 90° bend in one end of the wire. Place a 1/2", 90° bend in the other end. Solder the 1/2" end to terminal 4 of T-3. Solder the other end to pin 7 of V-4.

READ SUPPLEMENT

- ✓ 16" single conductor shielded cable. From both ends of the cable, strip away 1" outer insulation and 1/4" inner insulation. Remove the shield wire from one end of the cable.
- ✓ At the end of the cable with the shield wire, solder the inner conductor to terminal 2 of S-4. Solder the shield wire to the solder lug attached to S-4 (2 wires). Route the cable as shown.
- ✓ At the other end of the cable, connect the inner conductor to pin 5 of V-4.

PARTS MOUNTING—TOP

SEE FIGURE 12.

- ✓ U-shaped bracket and two 1/4" grommets. Insert a grommet in each of the small holes in the bottom of the bracket.

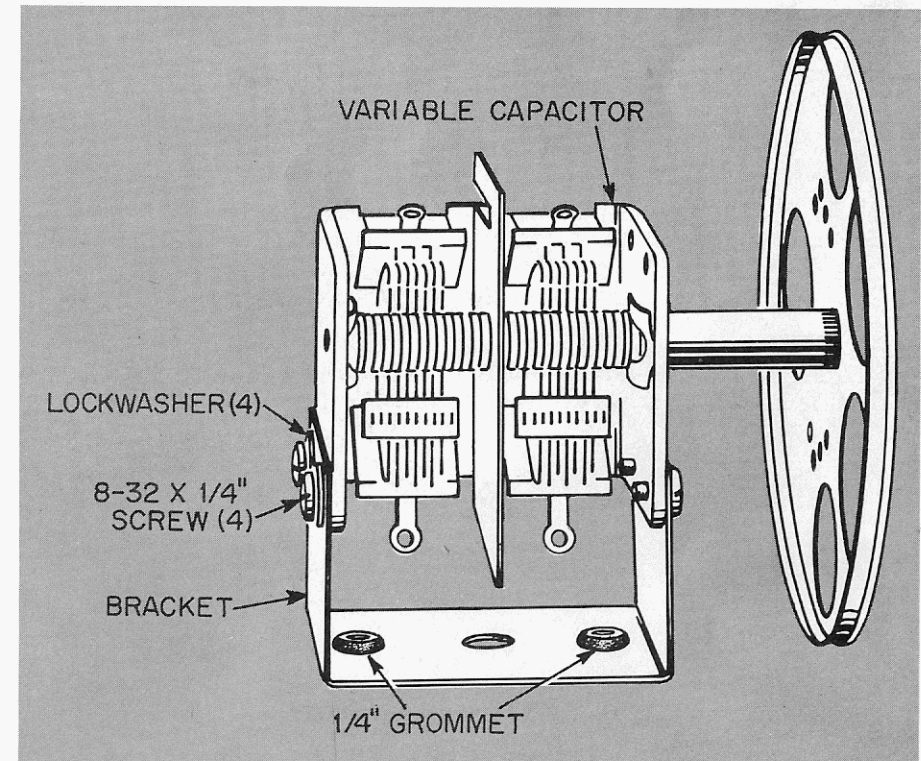

FIGURE 12



PARTS MOUNTING—TOP

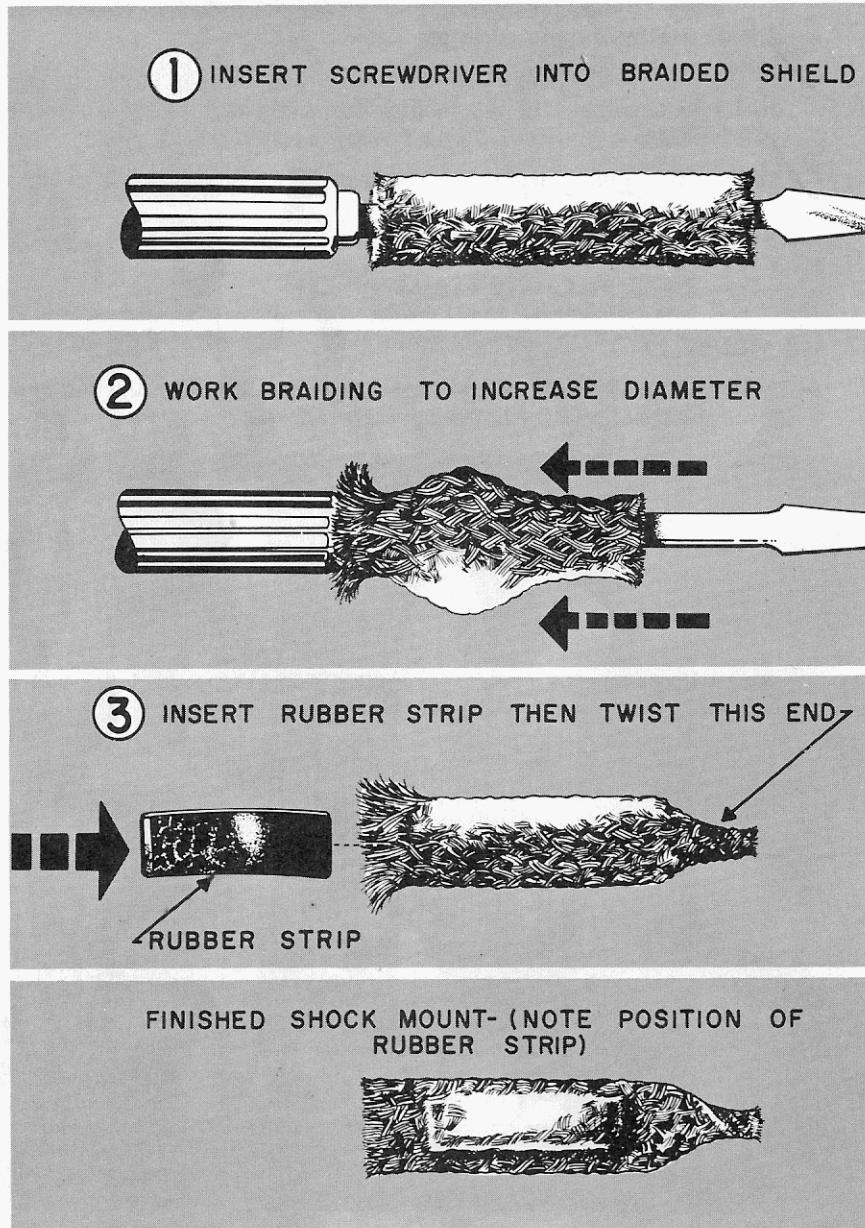

FIGURE 13

✓ MOUNT the bracket to one of the variable capacitors with pulley wheel attached. Fasten with four 8-32 x ¼" screws and lockwashers. BE CAREFUL NOT TO BEND ANY OF THE PLATES OF THE CAPACITOR.

✓ Repeat the above two steps for assembling and mounting the second U-shaped bracket to the remaining variable capacitor.

SEE FIGURE 13.

✓ Shock mount for C-1. From the pad of rubber supplied, cut a strip 1½" long and ¼" wide. DO NOT REMOVE THE PLASTIC BACKING. Insert the rubber strip in one of the lengths of braided shield. This is best done by working the shield into a large diameter with a screwdriver, then inserting the rubber strip and tightening the shield around it. Twist the strands at one end of the shield.

✓ Shock mount for C-2. To prepare, repeat the above step.

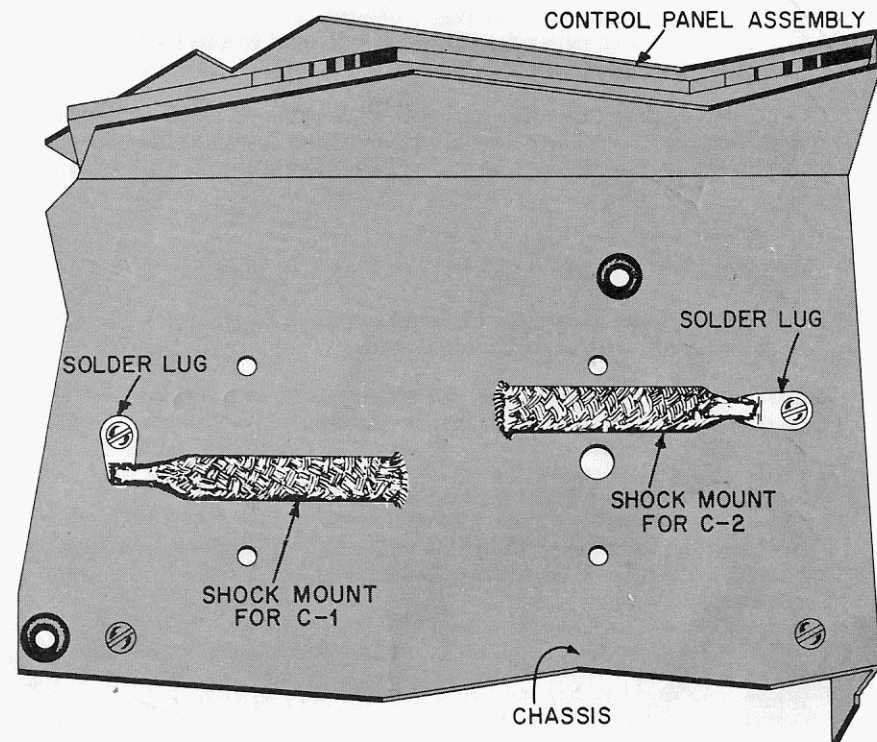

FIGURE 14



SEE FIGURES 14 AND 15.

- ☑ Mount two solder lugs to the top of the chassis as shown. Fasten with two 4-40 x $\frac{3}{8}$ " screws and nuts. DO NOT TIGHTEN NUTS.
- ☑ Solder the twisted end of a shock mount to each of the solder lugs. POSITION THE SHOCK MOUNTS EXACTLY AS SHOWN. TIGHTEN THE MOUNTING NUTS.

SEE FIGURE 15 ON SEPARATE SHEET.

- ☐ C-1 assembly (variable capacitor with **largest number of plates** and shortest shaft). Mount to the chassis as shown in Figure 16. Fasten with two 4-40 x $\frac{3}{8}$ " screws, two flat metal washers, two lockwashers and two nuts. Place the flat washers over the screws. Insert the screws through the grommets in the bracket. Loosely fasten to the chassis with a lockwasher and nut. Position the braided shield so it crosses the large hole in the center of the bracket. Tighten the mounting nuts. Do not overtighten.
- ☐ Solder the shield to the bracket *ON SIDE* at the point shown. **Apply solder sparingly.** *NEAREST SOLDER LUG.*
- ☐ C-2 assembly (variable capacitor with smallest number of plates and longest shaft). Similarly mount this assembly to the chassis, making sure that the braided shield goes **between the front mounting screw and center hole** of the bracket.
- ☐ Solder the shield to the bracket at the point shown. **Apply solder sparingly.**

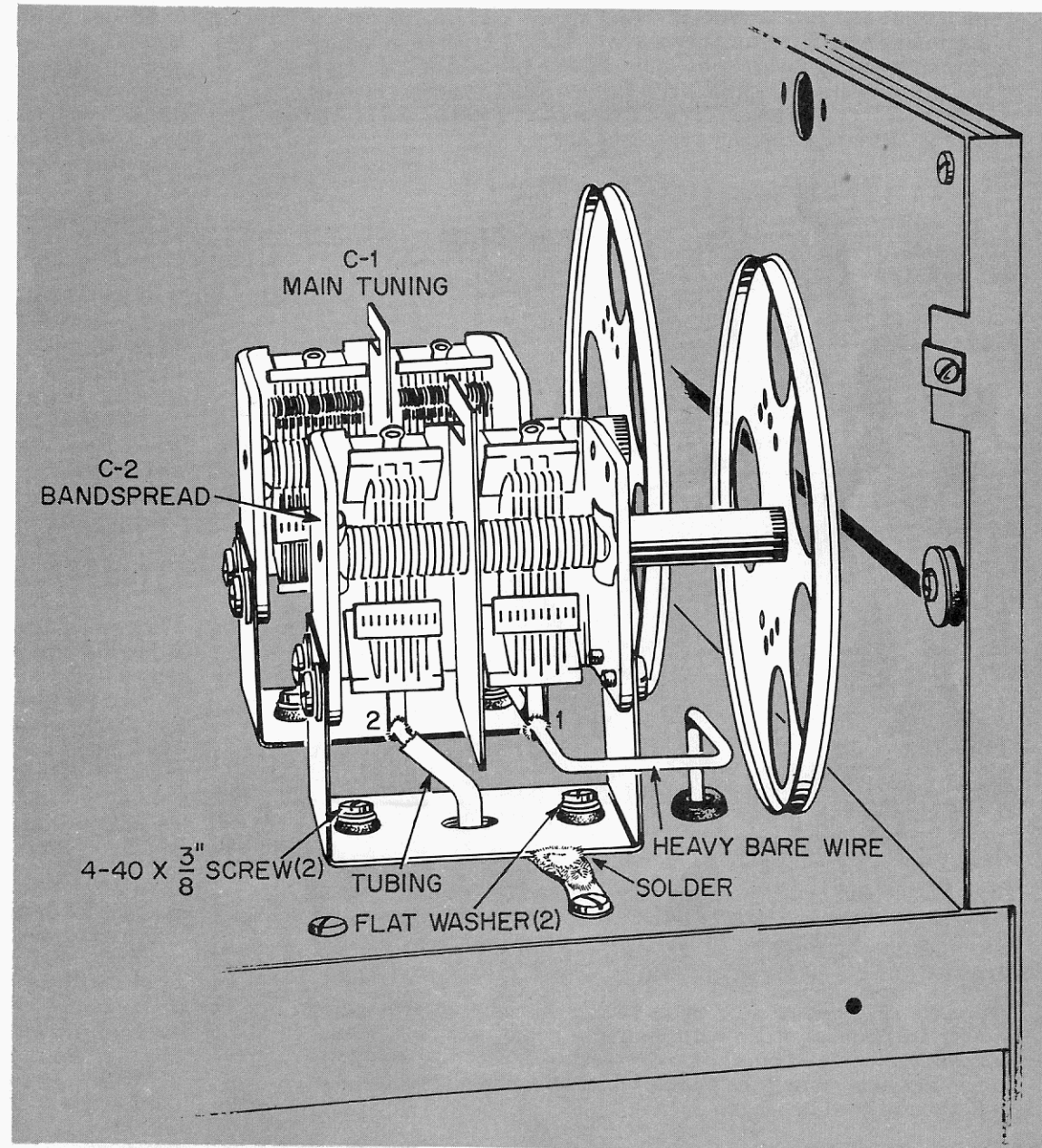
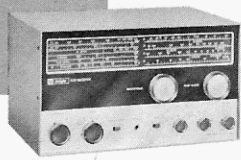

FIGURE 16



- Tuning shaft and two C washers. See Figure 17. Place a C washer in the groove near the center of the shaft. Lock it in place by pinching the ends of the washer with your longnose pliers. From the back of the control panel, insert the shaft through the $\frac{3}{8}$ " bushing marked BANDSPREAD. Place the second C washer in the remaining groove and lock it in place with your longnose pliers.

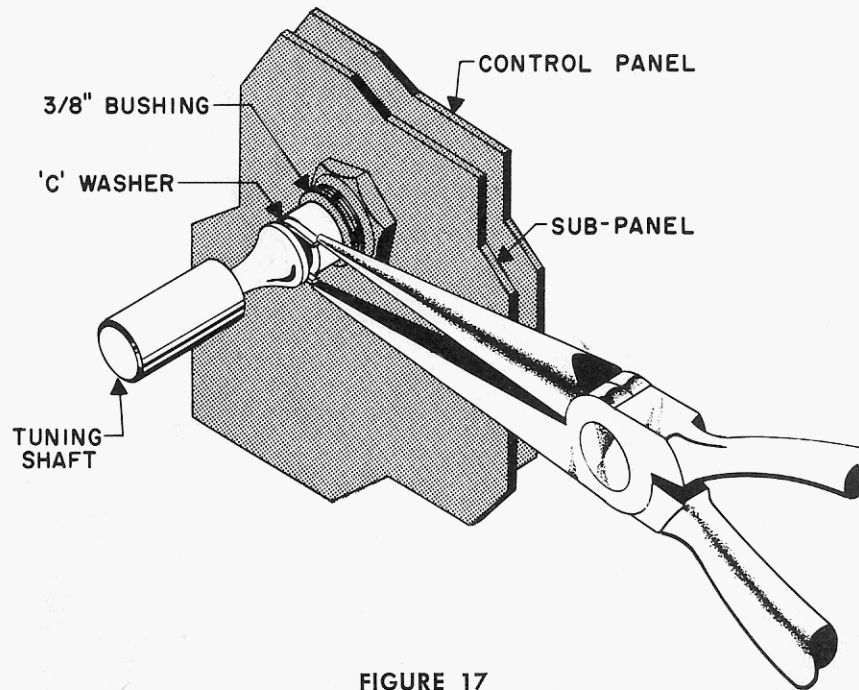

FIGURE 17

- Tuning shaft and two C washers. Similarly mount this tuning shaft in the bushing marked MAIN TUNING.

SEE FIGURE 18.

- Dial cord for stringing C-1, main tuning capacitor. See detail A. Loosely tie one end of the cord around a length of yellow tubing. Remove the tubing. From the knot, measure off $51\frac{1}{2}$ ". At this point tie another loop around the yellow tubing. Remove the tubing. Cut OFF the excess cord length.

- Place one of the loops on the tab of the large pulley (C-1) labeled START in Figure 18. Bring the cord up through the rim opening and half way around the pulley. Follow arrows. The cord leaves the bottom of the large pulley, is threaded around small pulleys 1 and 2 (2 is closer to sub-panel), around the tuning shaft for $2\frac{1}{2}$ turns and back over the top of the large pulley for 1 turn. Hook a spring in the loop at the end of the cord. Feed the cord through the rim opening and hook the end of the spring around the tab labeled FINISH. By rotating the tuning shaft, the capacitor should open and close freely. Make sure sections of the dial cord DO NOT RUB against each other as you rotate the shaft.
- Red dial pointer. See Figure 18, Detail B. Rotate the tuning shaft of the MAIN TUNING capacitor until the plates are fully open. Make sure the pointer is not bent and that it is properly seated on the sub-panel. Slide the pointer as far as you can toward small pulley wheel 1. Place the cord between the tabs of the pointer. Bend the center tab of the pointer over the cord to hold the pointer firmly in place. Rotate the shaft; the pointer should slide smoothly across the dial plate.

SEE FIGURE 19.

- Dial cord for stringing C-2, bandspread capacitor. See detail A. Tie two loops in the cord exactly $50\frac{1}{2}$ " apart. Remove excess cord length.
- Place one of the loops on the tab of the large pulley labeled START. Bring the cord up through the rim opening and half way around the pulley. Follow arrows. The cord leaves the bottom of the pulley and is threaded around small pulleys 3 and 4, around the tuning shaft for $2\frac{1}{2}$ turns and back over the top of the large pulley for 1 turn. Hook the remaining spring in the loop at the end of the cord. Bring the cord through the rim opening and hook the end of the spring around the tab labeled FINISH. Make sure the cord DOES NOT RUB at any point and that the capacitor opens and closes freely when you rotate the shaft.
- Green dial pointer. See Figure 19, Detail B. Rotate the shaft of the BANDSPREAD capacitor so the plates are fully closed. Slide the dial pointer as far as you can toward pulley wheel 4 and clamp the center tab of the pointer over the dial cord to hold the pointer firmly in place. Bend the three tabs that hold the dial cord at a slight upward angle, being careful that the pointer remains clamped on the cord. Rotate the shaft; the pointer should slide smoothly across the dial plate and come to rest just to the right of SET MAIN TUNING. If the pointer does not travel this far, increase the upward angle of the pointer tabs.

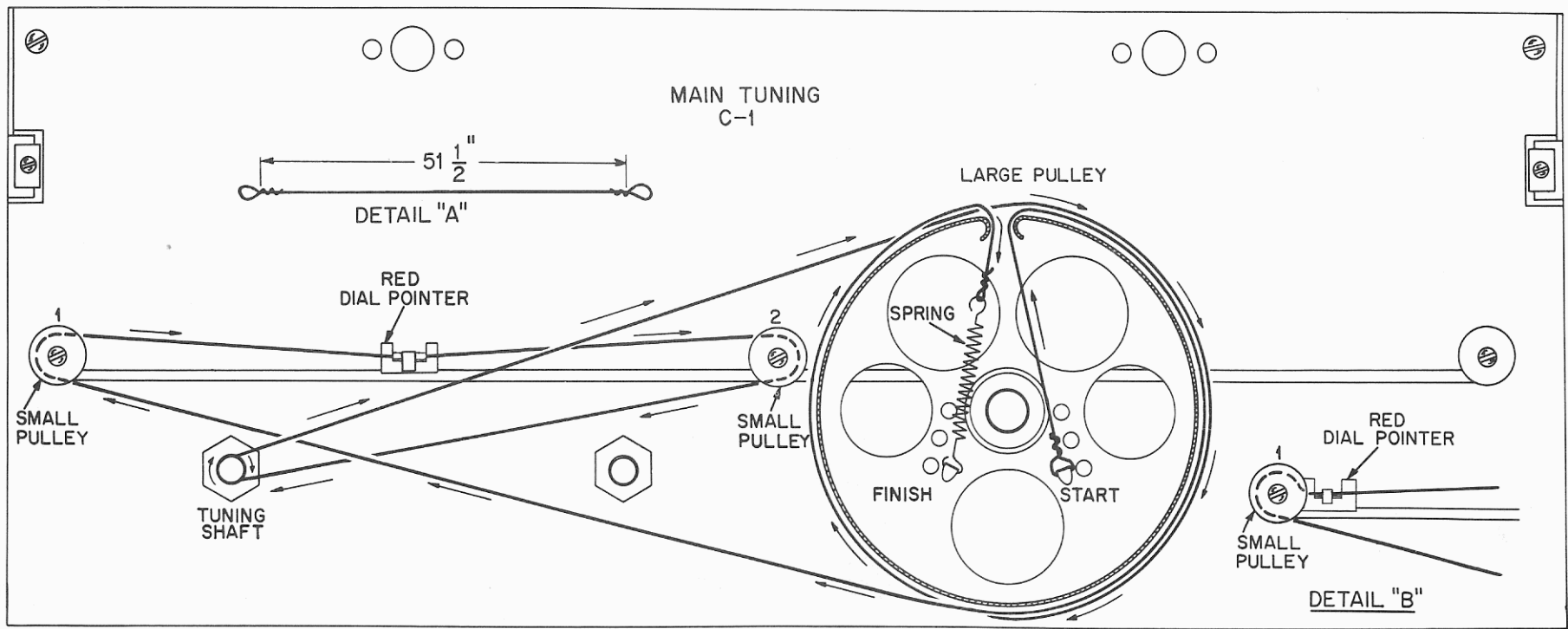
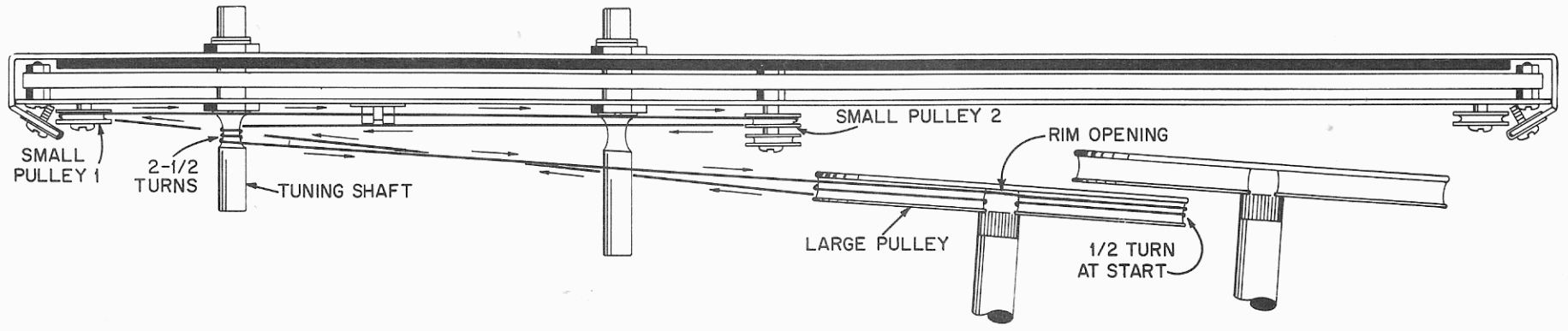
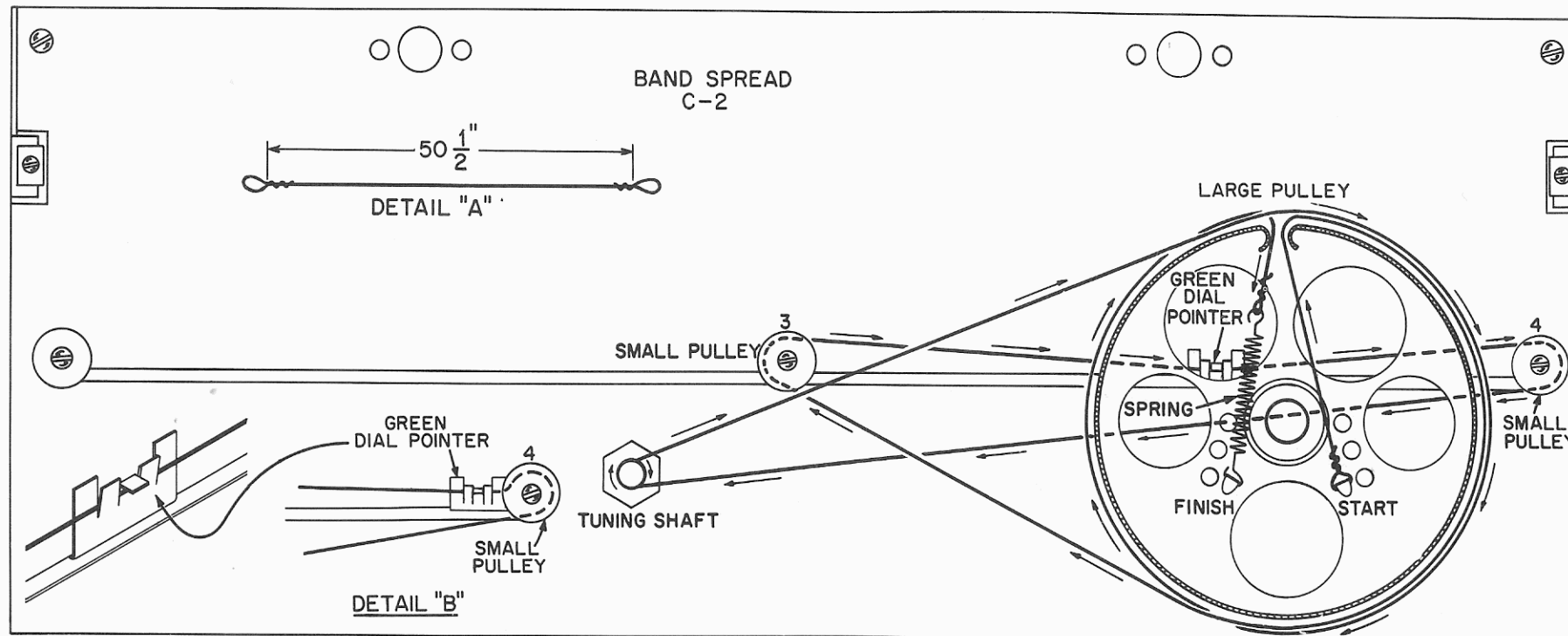
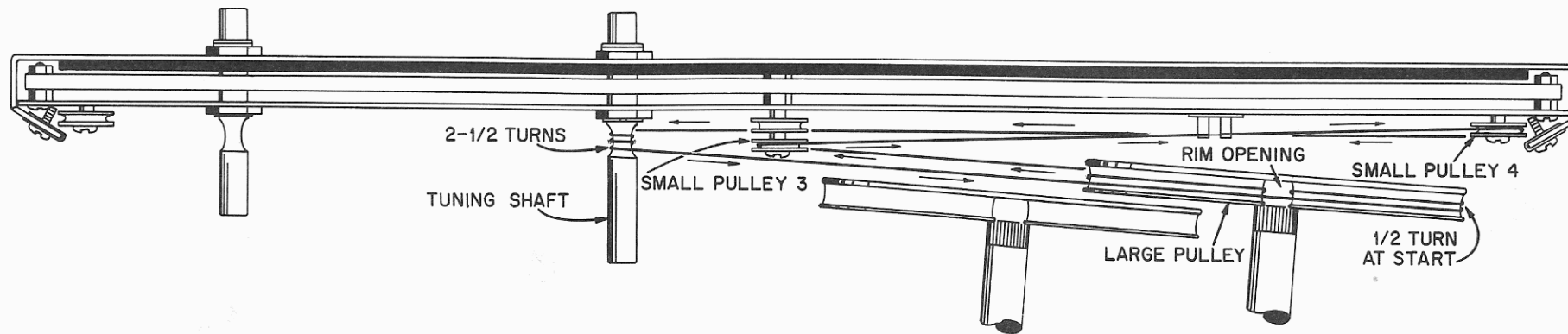



FIGURE 19



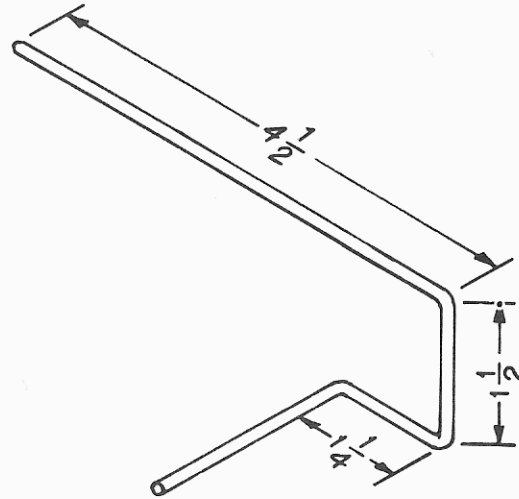

FIGURE 20

- ☑ 9½" heavy bare wire. Form this wire to the dimensions shown in Figure 20.

SEE FIGURE 16.

- ☑ Feed the long end of this wire through terminal 1 of C-2 and terminal 1 of C-1. These terminals are directly in line with each other at the bottom of the capacitors. Feed the other end of the wire through the grommet in the chassis. Solder terminal 1 of C-1 and C-2.
- ☑ 2½" heavy bare wire and 1¾" length of yellow tubing. Place the tubing over the wire. Feed one end of the wire through the hole in the chassis directly under C-2. Solder the other end to terminal 2 of C-2. Bend the free end of the wire slightly to hold the tubing in place.
- ☑ 5¼" heavy bare wire. Form this wire to the dimensions given in Figure 21.

SEE FIGURE 15 ON SEPARATE SHEET.

- ☑ Solder one end of the formed heavy bare wire to terminal 3 of C-2. Solder the other end to terminal 3 of C-1.
- ☑ Two flywheels and two setscrews. Start a setscrew in the threaded hole of each flywheel.
- ☑ Mount a flywheel to the BANDSPREAD tuning shaft with the flat side of the flywheel toward the sub-panel. Pull the top of the sub-panel away from the chassis slightly to facilitate mounting. Make sure the flywheel does not rub against the dial cord. Tighten the setscrew on the shaft.
- ☑ Similarly mount the remaining flywheel to the MAIN TUNING shaft.
- ☑ Two pilot lamps and sockets. Insert a pilot lamp in each of the sockets by firmly inserting the lamp and giving it a slight twist.
- ☑ Compress the ears on each socket and fit them into their mounting holes in the sub-panel.
- ☑ 2" length of red tubing. Twist the leads from each socket for a distance of 5", starting at the sockets. When you reach this point, twist the **black** leads from each socket together for the remainder of their length. Similarly twist the **red** leads. Slip the red tubing over all four leads.
- ☑ Solder the two black leads to the solder lug attached to V-2. Feed the pair of red leads through the grommet in the chassis.
- ☑ Bare lead from T-4. Connect this lead to the solder lug attached to T-4.
- ☑ White wire. Solder one end to the solder lug attached to T-4 (2 wires). The free end will be connected later.

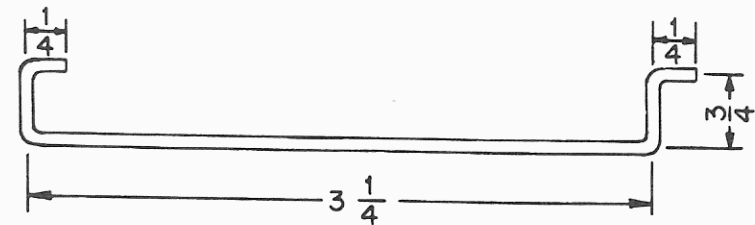

FIGURE 21



SEE FIGURE 22.

- Back mounting plate and $\frac{3}{8}$ " rubber grommet. Mount a rubber grommet in the large hole of the back mounting plate.
- Switch S-1 with bracket, and front and back mounting plates. Remove the $\frac{3}{8}$ " nut from S-1 if it has one. Attach the two mounting plates to the bracket on S-1 and fasten with two 4-40 x $\frac{3}{8}$ " screws, lockwashers and nuts, as shown.

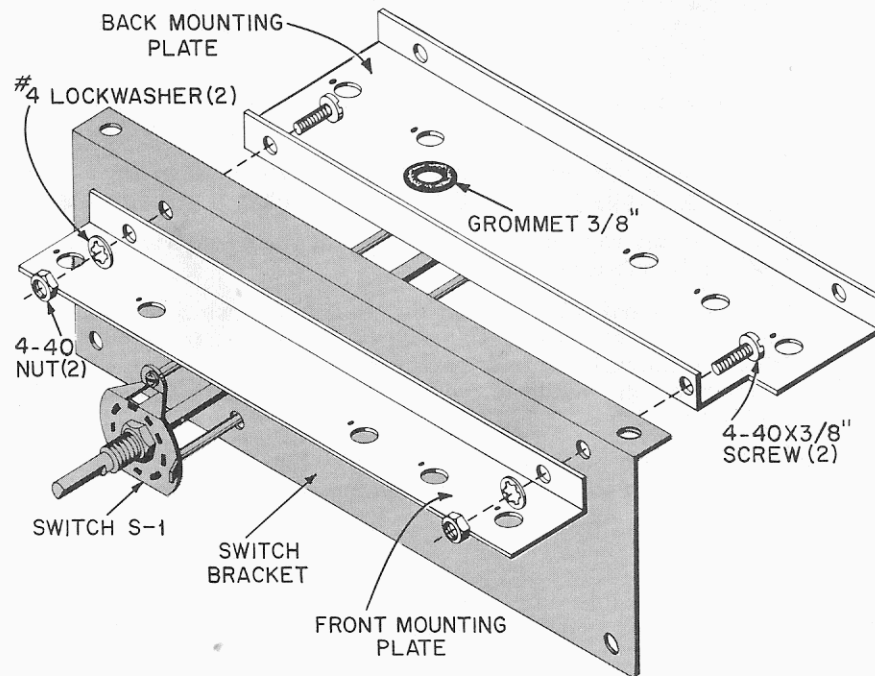

FIGURE 22

COIL MOUNTING

SEE FIGURE 23.

- Two solder lugs. Attach to the switch bracket as shown. Fasten with two 4-40 x $\frac{3}{8}$ " screws and nuts. Solder both solder lugs to the switch bracket. DO NOT FILL THE WIRE HOLES WITH SOLDER.

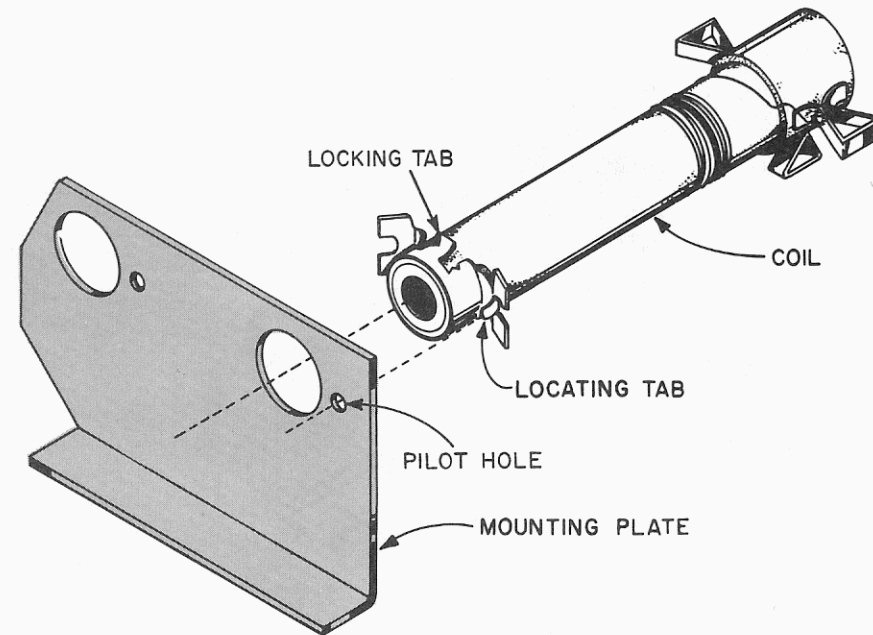

FIGURE 24

- Coil L-6 (blue dot). Mount L-6 to the front mounting plate, See Figure 24. Make sure both locking tabs hold the coil to the mounting plate and the locating tab is in the pilot hole.

Similarly mount the following coils to the front mounting plate.

- L-7 (violet dot)
- L-10 (black dot)
- L-9 (white dot)
- L-8 (gray dot)

Similarly mount the following coils to the back mounting plate.

- L-1 (brown dot)
- L-2 (red dot)
- L-5 (green dot)
- L-4 (yellow dot)
- L-3* (orange dot)

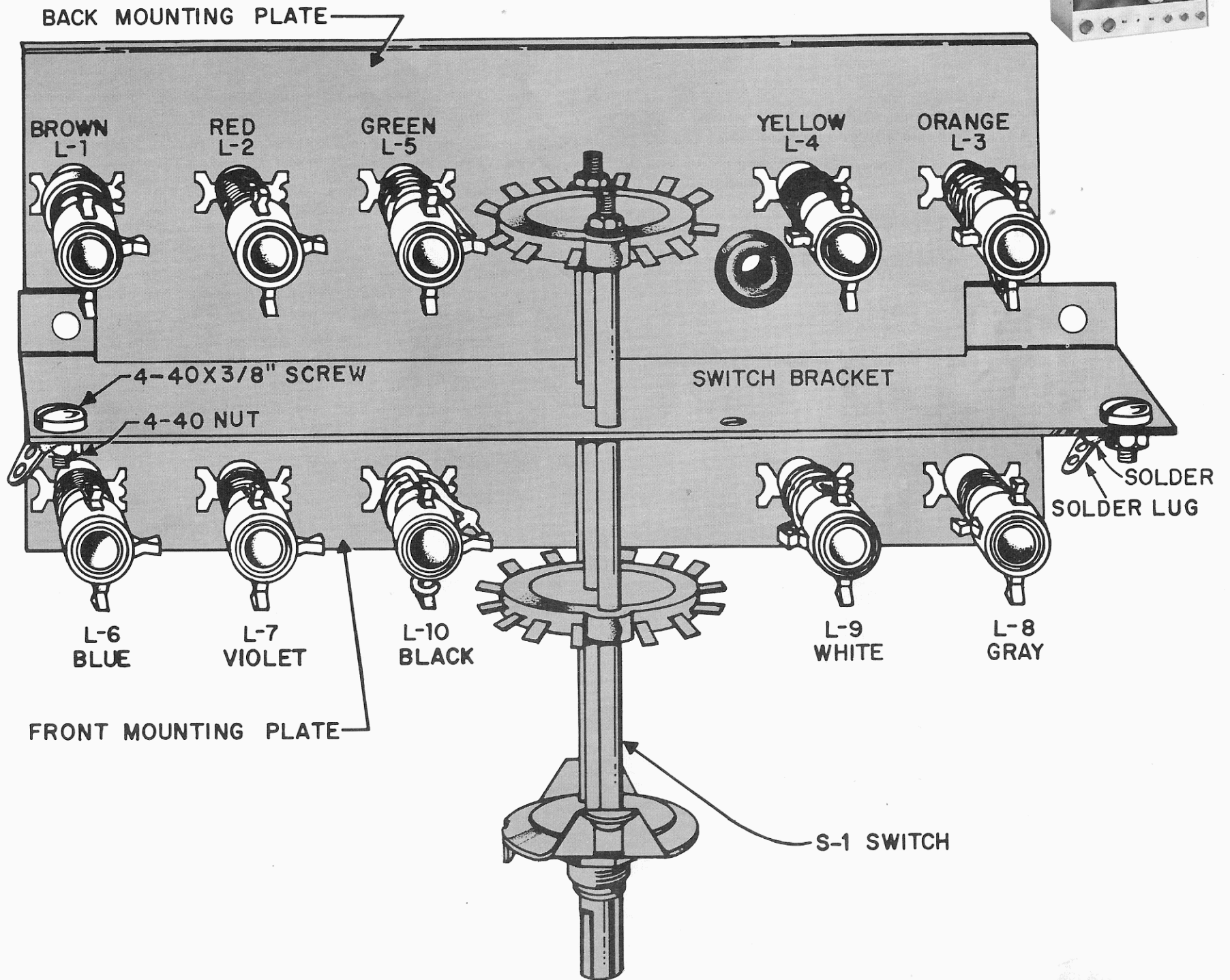



WIRING COIL ASSEMBLY

SEE FIGURE 25.

NOTE: When wiring S-1, it is important to route the wires exactly as shown.

Wafer 1 of S-1 (front wafer).

- X 1" thin bare wire. Solder one end to terminal 3 of S-1. Solder the other end to terminal 1 of L-9.
- X Red wire. Solder one end to terminal 11 of S-1. Solder the other end to terminal 2 of L-10.
- X Orange wire. Solder one end to terminal 4 of S-1. Solder the other end to terminal 1 of L-10.
- X Yellow wire. Solder one end to terminal 9 of S-1. Solder the other end to terminal 2 of L-8.
- X Yellow wire. Solder one end to terminal 8 of S-1. Solder the other end to terminal 1 of L-7.

- X Orange wire. Solder one end to terminal 10 of S-1. Solder the other end to terminal 2 of L-9.
- X Green wire. Solder one end to terminal 7 of S-1. Solder the other end to terminal 1 of L-6.
- X 5¼" heavy bare wire, and 4" yellow tubing. At one end of the wire place a 90° bend ½" long. Solder this end of the wire to terminal 5 of S-1. Slip the yellow tubing over the wire and bend the free end of the wire to the shape shown. Each bend is ¼" long.
- X 5½" heavy bare wire and 4" yellow tubing. Solder one end of the wire to terminal 12 of S-1. Slip the tubing over the wire and place a 90° bend in the free end of the wire 1¼" long.
- X 12¼" heavy bare wire, two 2½" and one 5¾" lengths of yellow tubing. Place the tubing over the wire and form the wire to the dimensions shown in Figure 26.
- X 1½" heavy bare wire. Form the wire as shown and solder it to the 12¼" heavy bare wire at the point indicated.

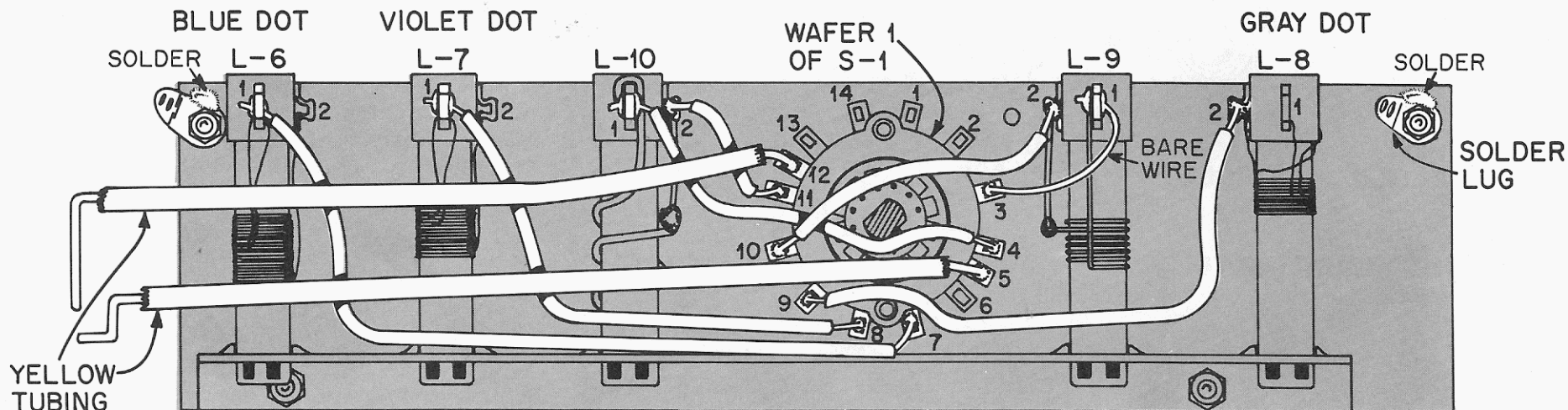

FRONT OF S-1 REMOVED FOR CLARITY

FIGURE 25



Wafer 2 of S-1.

SEE FIGURE 27 ON SEPARATE SHEET.

- X Formed heavy bare wire. Feed the wire through the space between the center shaft and lower screw of S-1. Solder the wire to terminal 5 of S-1.
- X Yellow wire. Solder one end to terminal 2 of L-3. Solder the other end to terminal 8 of S-1.
- X Orange wire. Solder one end to terminal 1 of L-5. Solder the other end to terminal 4 of S-1.
- X 1" thin bare wire. Solder one end to terminal 2 of L-5. Solder the other end to terminal 10 of S-1.
- X Orange wire. Solder one end to terminal 2 of L-2. Solder the other end to terminal 7 of S-1.
- X Green wire. Solder one end to terminal 2 of L-1. Solder the other end to terminal 6 of S-1.
- X Orange wire. Solder one end to terminal 2 of L-4. Solder the other end to terminal 9 of S-1.

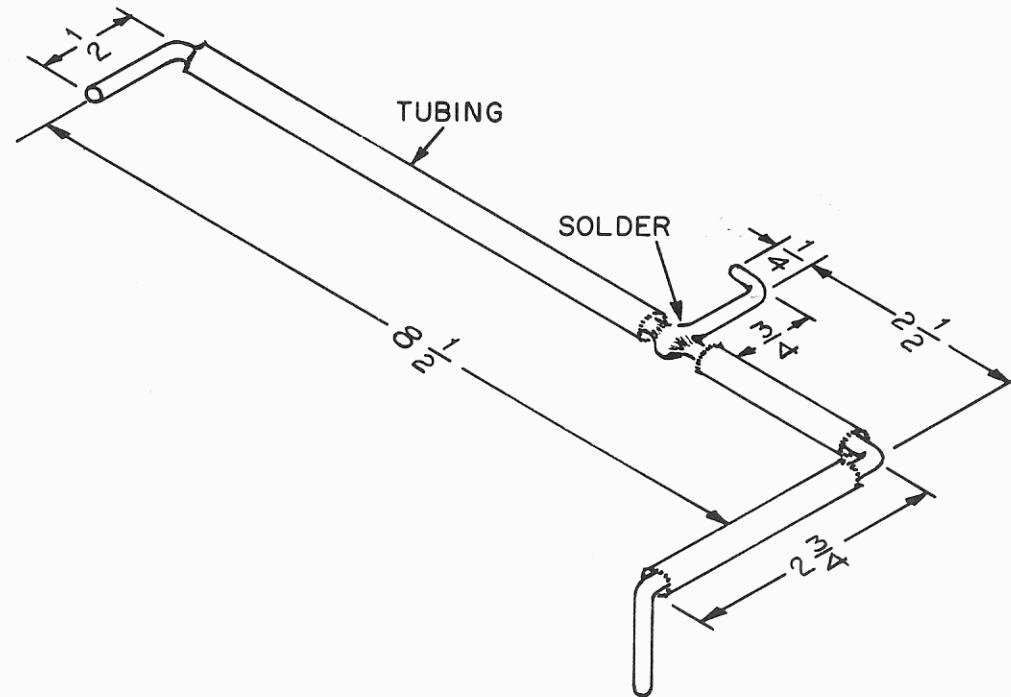
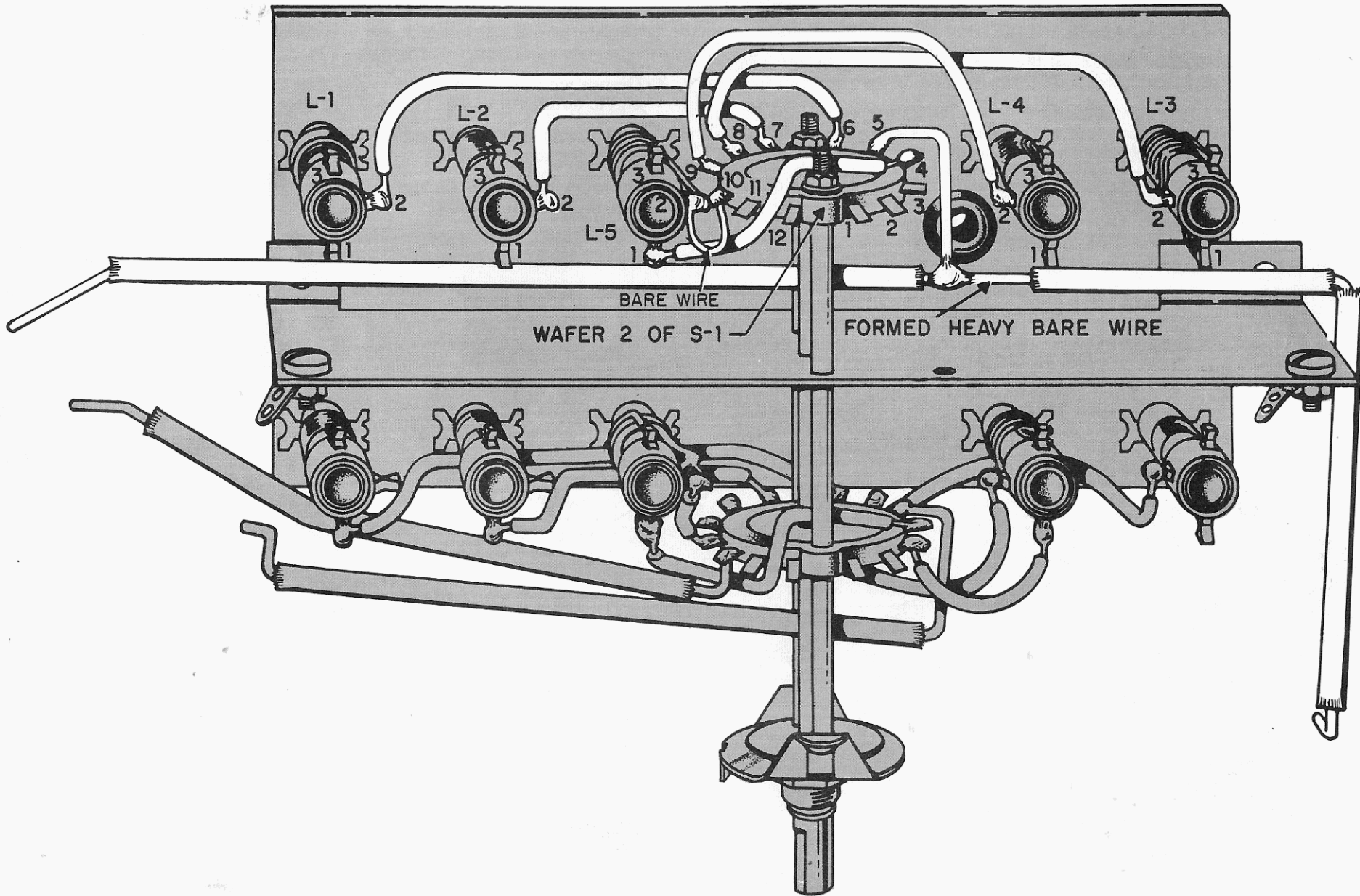

FIGURE 26



FIGURE 27



DM



SEE FIGURE 28 ON SEPARATE SHEET.

- R-18, 180Ω resistor (brown, gray, brown) and C-23, .05 μf disc capacitor. Wrap the leads of C-23 around the leads of R-18. Solder both leads and cut the excess lead lengths.
- Solder one lead of the R-18 combination to the center pin of V-3 (2 wires). Solder the other lead to pin 6 of V-3 (3 wires).
- C-35, .01 μf disc capacitor. Solder one lead to terminal 3 of TS-6 (2 wires). Solder the other lead to pin 5 of V-4 (3 wires).
- C-17, .01 μf disc capacitor. Solder one lead to pin 1 of V-5 (2 wires). Solder the other lead to the center pin of V-5 (4 wires).
- Blue wire. Solder one end to terminal 4 of C-36 (2 wires). Connect the other end to terminal 1 of TS-7.
- C-43, .01 μf disc capacitor. Solder one lead to terminal 3 of TS-7 (4 wires). Connect the other lead to terminal 6.
- R-19, 47K resistor (yellow, violet, orange) and ¼" length of black tubing. Place the tubing over one lead. Solder this lead to terminal 6 of TS-7 (6 wires). Solder the other lead to pin 8 of V-3 (2 wires).
- ~~SMIT~~ Orange wire. Solder one end to terminal 3 of T-2. Solder the other end to pin 7 of V-3 (2 wires). Route wire as shown.
- C-16, .01 μf disc capacitor. Solder one lead to terminal 4 of TS-8 (3 wires). Solder the other lead to terminal 5 (4 wires).
- R-3, 2.7K resistor (red, violet, red). Solder one lead to terminal 4 of T-1 (2 wires). Connect the other lead to terminal 3 of TS-8.
- R-2, 12K 2 watt resistor (brown, red, orange). Solder one lead to terminal 3 of TS-8 (3 wires). Solder the other lead to pin 6 of V-1 (2 wires).
- Orange wire. Solder one end to terminal 3 of T-1. Solder the other end to pin 5 of V-1. Route wire as shown.
- Two red leads from the pilot sockets. Solder both leads to pin 3 of V-6 (4 wires).
- R-32, 1 meg resistor (brown, black, green). Solder one lead to terminal 5 of TS-7 (4 wires). Solder the other lead to terminal 4 (2 wires).

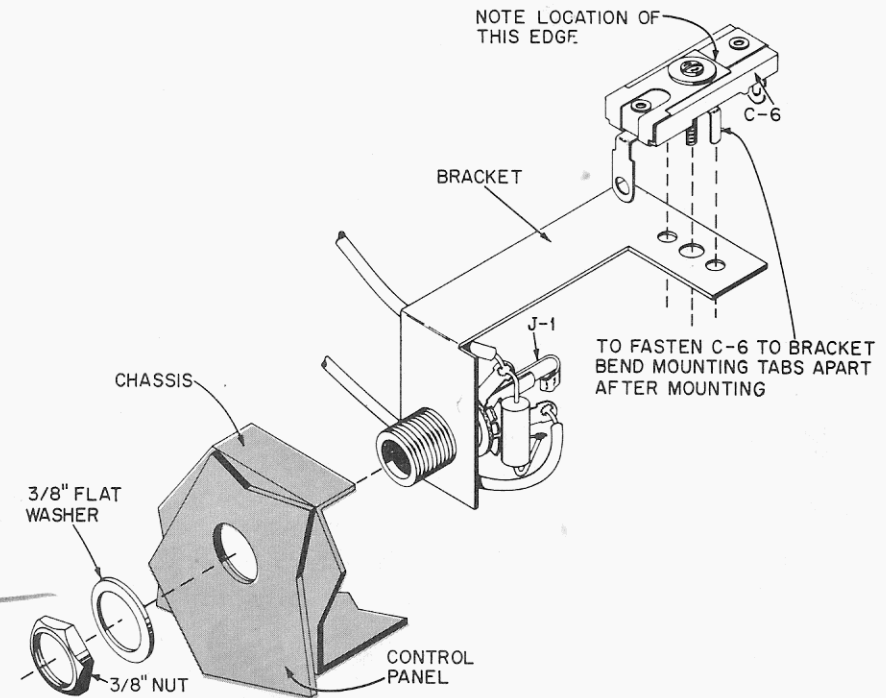

FIGURE 29

- C-6, 3-50 μμf trimmer capacitor and L shaped mounting bracket. Carefully study Figure 29. Position C-6 on the bracket exactly as it is shown. Insert the two mounting tabs in the holes in the bracket and bend them with your longnose pliers.
- Remove J-1 from its mounting hole. Insert J-1 through the L shaped mounting bracket, as shown and fasten this assembly to the chassis and control panel with a 3/8" flat metal washer and nut.
- Coil assembly. Remove the two nuts from the screws that hold the capacitor shock mounts. Mount the coil assembly to the chassis, as shown. Make sure the wire with the yellow tubing from C-2 comes through the grommet in the coil assembly. Loosely fasten with the two 4-40 x 3/8" screws that hold the capacitor shock mounts and two lockwashers and nuts. Thread a 3/8" nut over the front of S-1. Tighten the two 4-40 nuts.



THIRD WIRING—BOTTOM

- C-7, 500 $\mu\mu\text{f}$ mica capacitor and two 1" lengths of black tubing. DO NOT CUT THE LEADS. Place the tubing over the leads. Solder one lead to terminal 14 of wafer 1 on S-1. Connect the other lead to terminal 2 of C-6. Bend the terminals on C-6 as shown.
- $\frac{1}{2}$ " thin bare wire. Solder one end to terminal 2 of C-6 (2 wires). Solder the other end to terminal 2 of L-6.
- Heavy bare wire from terminal 5 of wafer 1. Solder the free end of this wire to terminal 2 of TS-9 (2 wires).
- Heavy bare wire from grommet near wafer 1. Solder this wire to the wire coming from terminal 5 of wafer 1.
- Heavy bare wire from terminal 5 wafer 2. Solder one end to terminal 1 of C-3. Solder the other end to pin 7 of V-1. Make sure wire does not touch chassis at any point.
- Heavy bare wire from grommet near wafer 2. Solder this wire to the wire from terminal 5 of wafer 2.
- Yellow wire. Solder one end to terminal 12 of wafer 2. Solder the other end to terminal 1 of L-1.
- White wire. Solder one end to terminal 11 of wafer 2. The free end will be connected later.
- Shield bracket and two solder lugs. Fasten the two solder lugs to the shield bracket with two 4-40 x $\frac{3}{8}$ " screws, lockwashers and nuts.
- Solder both solder lugs to the shield bracket. DO NOT FILL THE WIRE HOLES WITH SOLDER.
- Mount the shield bracket to the chassis as shown and fasten with two 4-40 x $\frac{3}{8}$ " screws, lockwashers and nuts.
- Feed the free end of the white wire from wafer 2 through the large hole in the center of the shield bracket. Solder the wire to terminal 1 of TS-1.
- Solder the free end of the heavy bare wire from terminal 12 of wafer 1 to pin 2 of V-1.
- $5\frac{3}{4}$ " heavy bare wire. From this wire to the dimensions shown in Figure 30. Solder the end with the short bend to terminal 13 of wafer 1. Solder the other end to terminal 1 of TS-9 (2 wires).
- Solder terminal 1 of C-6 to the heavy bare wire at the point shown.
- 8" heavy bare wire. Feed this wire through terminal 3 of coils L-8, L-9, L-10, L-7 and L-6. Solder one end of the wire to the solder lug near L-6. Connect the other end of the wire in the bottom hole of the solder lug near L-8.
- Solder terminal 3 of all five coils.
- 8" heavy bare wire. Feed this wire through terminal 3 of coils L-3, L-4, L-5, L-2 and L-1. Solder one end of the wire to the solder lug near L-1. Connect the other end of the wire in the bottom hole of the solder lug near L-3.
- Solder terminal 3 of all five coils.
- 4" heavy bare wire. Feed the wire through the top hole of the solder lug near L-8. Solder one end of the wire to the solder lug near L-3 (2 wires). Solder the other end to the solder lug attached to the bracket of C-3.
- Solder the wires in the solder lug near L-8 (2 wires).
- R-16, 220K resistor (red, red, yellow) and two $\frac{1}{2}$ " lengths of black tubing. Cut each lead to $\frac{3}{4}$ ". Place the tubing over the leads. Solder one lead to pin 3 of V-3 (2 wires). Solder the other lead to terminal 1 of TS-7 (4 wires). *changed to 150K*
- C-44, .01 μf disc capacitor. Solder one lead to pin 8 of V-5 (3 wires). Solder the other lead to pin 9 (2 wires).

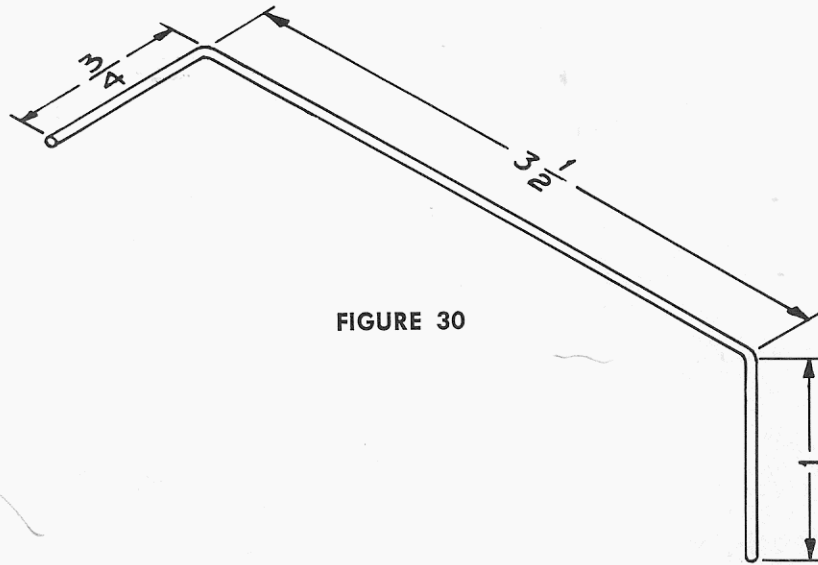

FIGURE 30

FINAL WIRING OF COIL ASSEMBLY

SEE FIGURE 31 ON SEPARATE SHEET.

- Red wire. Solder one end to terminal 3 of wafer 2. Solder the other end to terminal 1 of L-4.
- Red wire. Solder one end to terminal 2 of wafer 2. Solder the other end to terminal 1 of L-3.
- Orange wire. Solder one end to terminal 1 of wafer 2. Solder the other end to terminal 1 of L-2.
- Red wire. Solder one end to terminal 2 of wafer 1. Solder the other end to terminal 1 of L-8.
- C-41, 620 μf capacitor and two $\frac{3}{4}$ " lengths of black tubing. Cut each lead to 1". Place the tubing over the leads. Solder one lead to terminal 1 of wafer 1. Solder the other lead to terminal 2 of L-7. ✓
- CAREFULLY CHECK EVERY CONNECTION FOR—NO SOLDER, TOO LITTLE SOLDER OR TOO MUCH SOLDER.** If a solder connection appears to be doubtful, reheat the connection.
- Bottom plate, four flat metal washers and four rubber feet. Mount the bottom plate to the bottom of the chassis so the tuning holes are centered over the coils. Line up the mounting holes and place a rubber foot over each hole. Place a washer in the recess of each foot. Fasten with four #6 x $\frac{3}{8}$ " self tapping screws.

MOUNTING KNOBS AND TUBES

- Two large diameter knobs. Place these knobs on the shafts of the BANDSPREAD and MAIN TUNING controls. Lock them in place by tightening their setscrews.
- Small knob with white dot. Rotate the shaft of the VOLUME control fully counterclockwise. Place the knob on the shaft so the white dot is in line with the word OFF printed on the chassis. Tighten the setscrew.
- Small knob with white dot. Rotate the shaft of the STANDBY, MVC, AVC, CAL switch fully counterclockwise. Mount the knob so the white dot is in line with STANDBY. Tighten the setscrew.
- Small knob with white dot. Mount on BFO shaft. Tighten the setscrew.
- Large knob with white dot. Mount this knob on the ANTENNA shaft. Tighten the setscrew.
- Large knob with white dot. Rotate the shaft of the BAND switch fully counterclockwise. Mount the knob on the shaft so the white dot is in line with A. Tighten the setscrew.
- Install the tubes in their sockets as shown in Figure 32.
- Place the ribbed tube shields over V-2, V-3, V-4 and V-5. Make sure the tube shields go over the shield clips attached to the sockets. V-4 receives the shorter shield.
- Install the remaining tube shield over V-1.
- Install fuse F-1 in the fuse holder.
- 1" heavy bare wire. Connect this wire across the two terminals of TS-2 (remote).
- LS-1. Solder the white wire from the solder lug attached to T-4 to one of the terminals on the loudspeaker. Solder the red/white/black wire from the grommet to the other terminal on the loudspeaker.

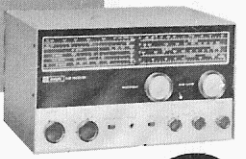
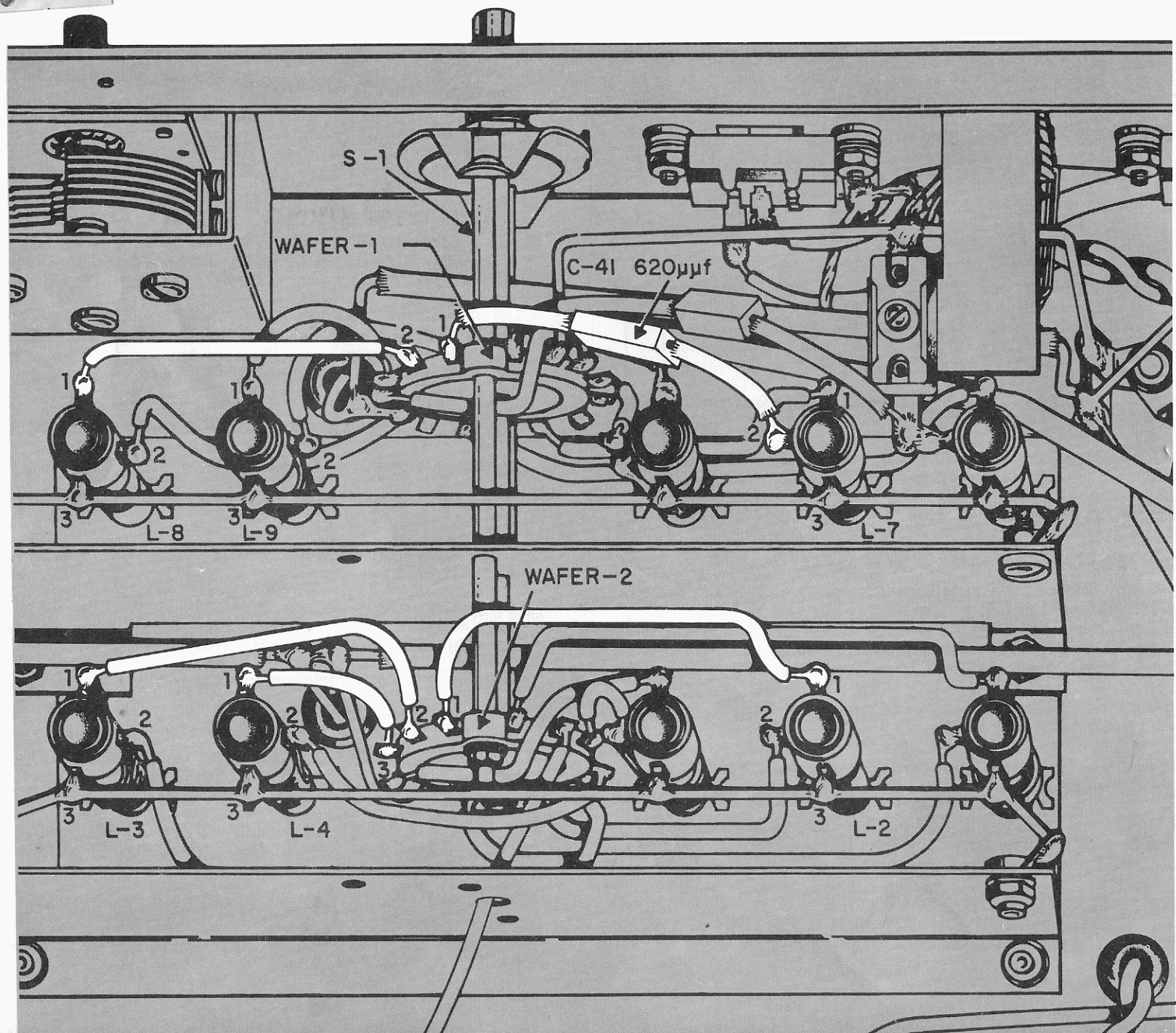
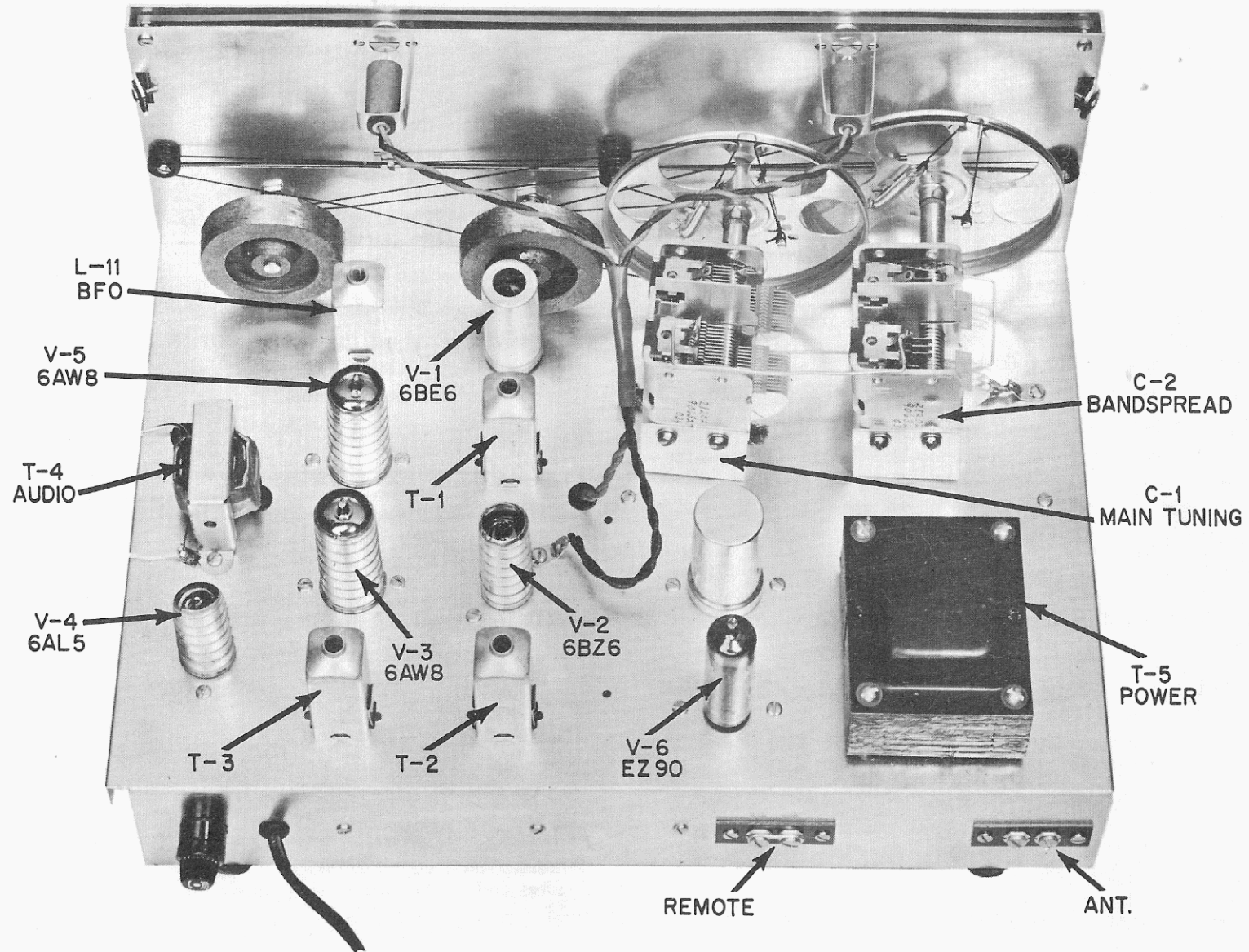
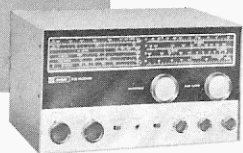

FIGURE 31







For alignment of all bands, the controls should be set as follows unless otherwise stated.

VOLUME set to maximum

BFO set to OFF

NOISE LIMITER set to OFF

STANDBY-MVC-AVC-CAL set to ~~AVC~~ MVC

BANDSPREAD pointer set to SET MAIN TUNING

BAND SWITCH set to band being aligned

I.F. ALIGNMENT. See Figure 32.

BAND A

.53mc to 1.9mc (broadcast band)

Connect an antenna to terminal 1 of TS-1 (marked ANT on the chassis). See section on antenna.

Plug the AC line cord in a 110 v. 60 cycle outlet.

At the low end of BAND A tune in a local broadcast station with the MAIN TUNING dial.

Insert the plastic tuning rod through the top of T-3 until it engages the bottom tuning slug. Adjust this slug for maximum volume, then adjust the top tuning slug for maximum.

Similarly adjust T-2, then T-1.

NOTE: L-1 to L-10 have been preadjusted at the factory. Only a slight adjustment will be necessary to peak these coils. These adjustments are made from the bottom of the chassis with the bottom cover attached.

BAND A

At the HIGH END of the band, tune in a local broadcast station whose frequency of transmission is known.

Simultaneously adjust the MAIN TUNING and C-6 until the signal being received is loudest and at the correct location on the dial.

Tune in a known frequency at the LOW END of the band.

Simultaneously adjust the MAIN TUNING and L-6 until the signal being received is loudest and at the correct location on the dial.

Without changing the MAIN TUNING dial, adjust L-1 for maximum volume. Because of interaction between C-6 and L-6 it will be necessary to repeat these adjustments several times for best accuracy.

BAND B

1.8mc to 6.3mc (80 meters)

Rotate the ANTENNA control until it is almost counterclockwise.

Tune in station WWV at 5mc. In some areas, WWV can only be received at night.

Simultaneously adjust the MAIN TUNING and L-7 until WWV is loudest and the dial pointer reads 5mc.

Adjust L-2 for maximum volume.

BAND C

6mc to 14.4mc (20 and 40 meters)

ANTENNA control to center of rotation.

Tune to station WWV at 10mc.

Simultaneously adjust the MAIN TUNING and L-8 until WWV is loudest and the dial pointer reads 10mc.

Tune L-3 for maximum volume.

BAND D

11.5mc to 33mc (10 and 15 meters)

ANTENNA control almost fully counterclockwise.

Tune to station WWV at 15mc. WWV can be received best during the day.

Simultaneously adjust MAIN TUNING and L-9 until WWV is loudest and the dial pointer reads 15mc.

Tune L-4 for maximum volume.

BAND E

47mc to 54mc (6 meters)

ANTENNA control almost fully clockwise.

MAIN TUNING set to 6 METERS.

Rotate the BANDSPREAD to a strong signal of known frequency.

Simultaneously adjust the BANDSPREAD and L-10 until the signal is loudest and at the correct location on the BANDSPREAD dial.

Tune L-5 for maximum volume.

**BFO**

STANDBY-MVC-AVC-CAL set to MVC

BFO set to ON

Tune to a strong signal on any band except the broadcast band (A).

As you rotate the BFO control a whistle should be heard. If not, adjust L-11 from the top of the chassis.

ALIGNMENT WITH INSTRUMENTS

EQUIPMENT REQUIRED

Voltmeter capable of reading down to 0.5 volts AC.

Signal generator with ranges from 530kc to 54mc. 30% modulation at 400 cycles.

300 $\mu\mu\text{f}$ capacitor.

SEE FIGURE 33.

Connect the coaxial cable to the generator as shown.

Connect one lead of the 300 $\mu\mu\text{f}$ capacitor to the ANT terminal. Connect the other lead to the center conductor of the coaxial cable coming from the signal generator. Connect the shield wire of the cable to the GR terminal of the receiver.

Connect the leads of the voltmeter to the speaker terminals.

STANDBY-MVC-AVC-CAL set to ~~AVC~~ MVC

NOISE LIMITER set to OFF

BFO set to OFF

NOTE: As the MAIN TUNING pointer is moved up scale, the ANTENNA control should be increased proportionately. That is, when the MAIN TUNING pointer is at the high end of the band the ANTENNA control should be almost fully clockwise (open); at the center of the band the ANTENNA control should be at mid-rotation; at the low end of the band the ANTENNA control should be almost fully counterclockwise (closed).

Follow the instructions on the alignment chart.

ALIGNMENT CHART

| BAND | MAIN TUNING MC | BAND SPREAD | SIGNAL GENERATOR MC | ANTENNA CONTROL | ADJUST FOR MAXIMUM |
|------|----------------|-----------------|---------------------|-----------------|--------------------|
| A | .53 | SET MAIN TUNING | 1.65 | *OPEN | T-3 TOP & BOTTOM |
| A | SAME | SAME | SAME | SAME | T-2 |
| A | SAME | SAME | SAME | SAME | T-1 |

REPEAT FIRST THREE STEPS

| | | | | | |
|---|-----|-----------------|-----|----------|-----|
| A | .53 | SET MAIN TUNING | .53 | **CLOSED | L-6 |
| A | 1.9 | SAME | 1.9 | OPEN | C-6 |

REPEAT ABOVE TWO STEPS

| | | | | | |
|---|------|-----------------|------|---------------|------|
| A | .6 | SET MAIN TUNING | .6 | ALMOST CLOSED | L-1 |
| B | 1.9 | SAME | 1.9 | SAME | L-7 |
| B | 2.5 | SAME | 2.5 | 1/4 OPEN | L-2 |
| C | 6.0 | SAME | 6.0 | SAME | L-8 |
| C | 6.0 | SAME | 6.0 | SAME | L-3 |
| D | 11.5 | SAME | 11.5 | SAME | L-9 |
| D | 11.5 | SAME | 11.5 | SAME | L-4 |
| E | 6M | 50 | 50 | ALMOST OPEN | L-10 |

*****SET GENERATOR AT 46.8Mc AND CHECK FOR IMAGE**

| | | | | | |
|---|----|----|----|-------------|-----|
| E | 6M | 50 | 50 | ALMOST OPEN | L-5 |
|---|----|----|----|-------------|-----|

*OPEN means clockwise.

**CLOSED means counterclockwise.

***Leave MAIN TUNING at 50 Mc and set generator at 46.8 Mc. An image of the tone heard at 50 Mc should be heard at reduced volume. If you cannot hear this image, L-10 is tuned incorrectly.

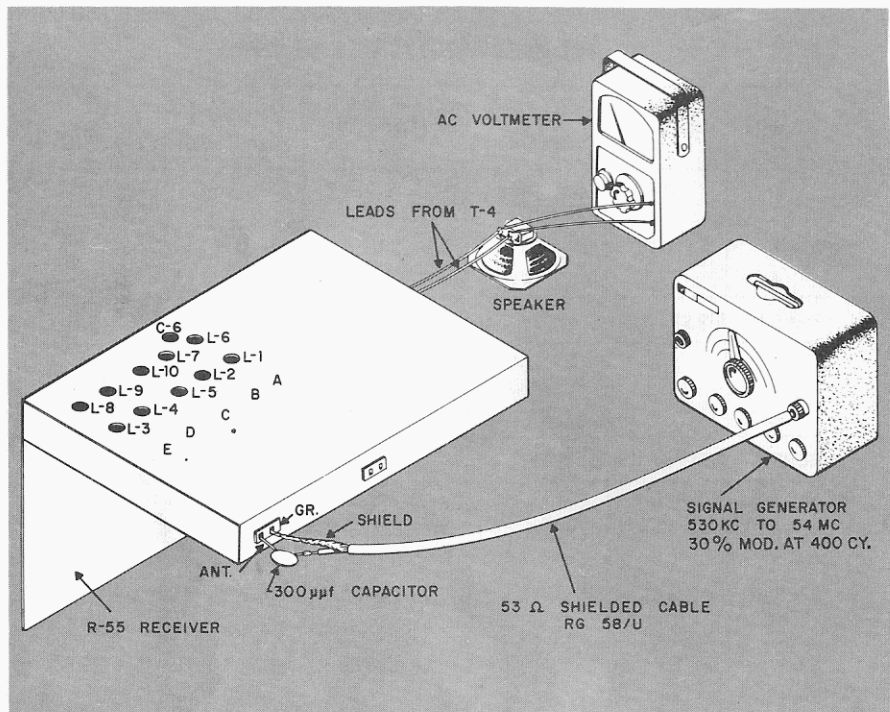

FIGURE 33

- Unsolder the two wires from the loudspeaker.

SPEAKER MOUNTING

SEE FIGURE 34.

- LS-1 and cabinet. Mount LS-1 in the cabinet so the speaker terminals point toward the bottom of the cabinet. Place a 1/4" grommet between the speaker and cabinet for each mounting hole. Fasten with four black 4-40 x 3/8" screws, flat washers and nuts.

SEE FIGURE 35.

- Place the cabinet alongside the chassis as shown and solder the White wire and red/white/black wire to the speaker terminals as you did previously.
- Mount the cabinet on the chassis with eight #4 x 1/4" black self tapping screws.

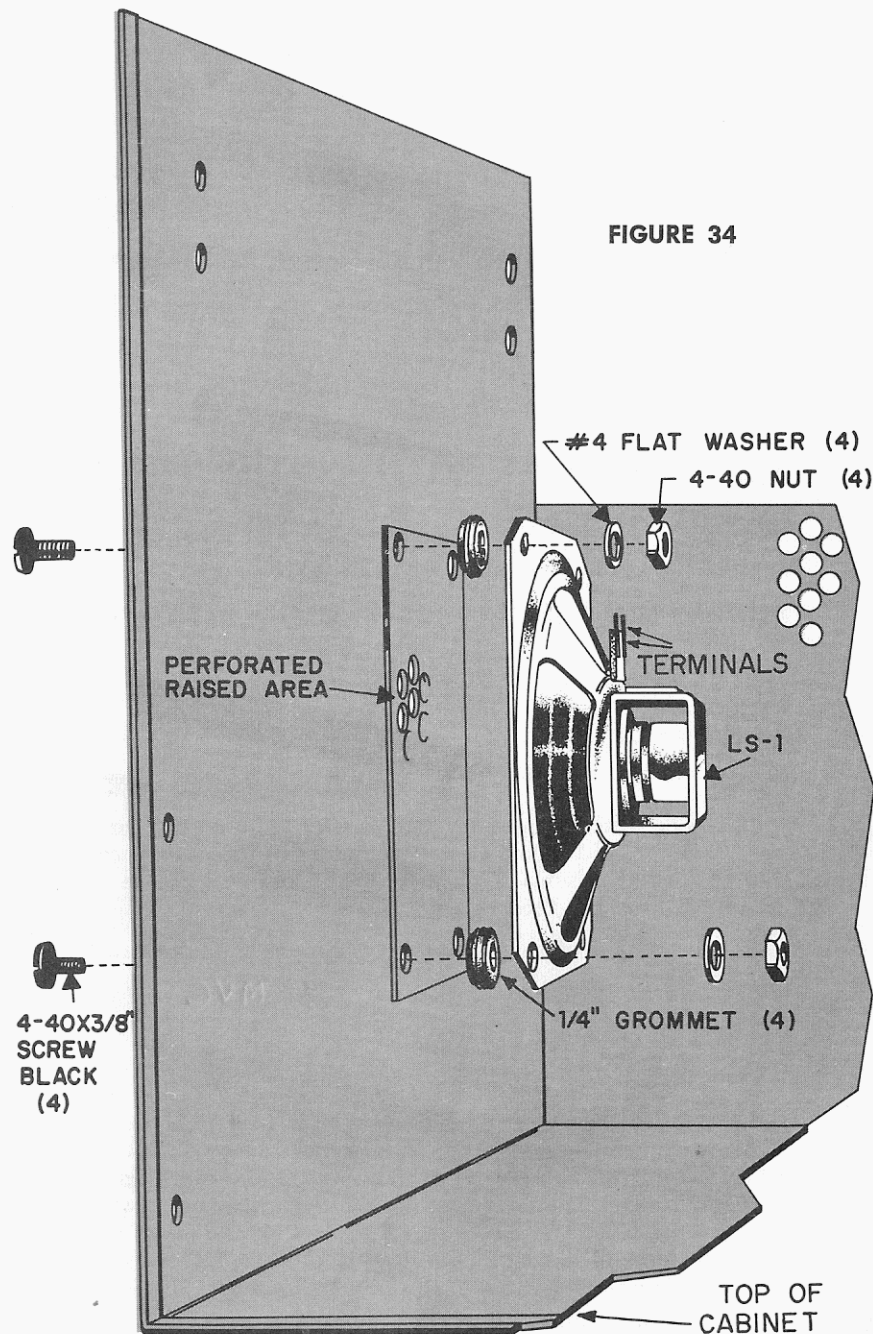

FIGURE 34



CONTROLS AND THEIR FUNCTIONS

ANTENNA CONTROL: Matches the RF tuned circuit to the antenna when there is a major change in frequency.

BAND SWITCH: Selects the band of frequencies desired.

NOISE LIMITER SWITCH: Reduces impulse noises generated by automobile ignitions and household appliances.

PHONES: Jack provided for headphone listening. When this jack is used the loudspeaker is muted.

BFO SWITCH AND CONTROL: The switch turns the BFO ON or OFF. The control varies the pitch of the audio tone in the speaker. The STANDBY-MVC-AVC-CAL switch should always be set to the MVC position when using the BFO.

STANDBY-MVC-AVC-CAL.

STANDBY: Keeps the receiver energized but mutes the speaker.

MVC: Manual volume control used for receiving weak signals.

AVC: Automatic volume control helps keep volume at a constant level.

CAL: Use in conjunction with crystal calibrator to check frequency alignment of the receiver.

OFF-VOLUME CONTROL: Used to vary loudness of signal from speaker and turns power ON or OFF.

MAIN TUNING: Selects a specific signal from a band of frequencies.

BANDSPREAD: Expanded scale of the frequencies contained in the band for which MAIN TUNING is set. Allows you to more accurately tune a specific signal.

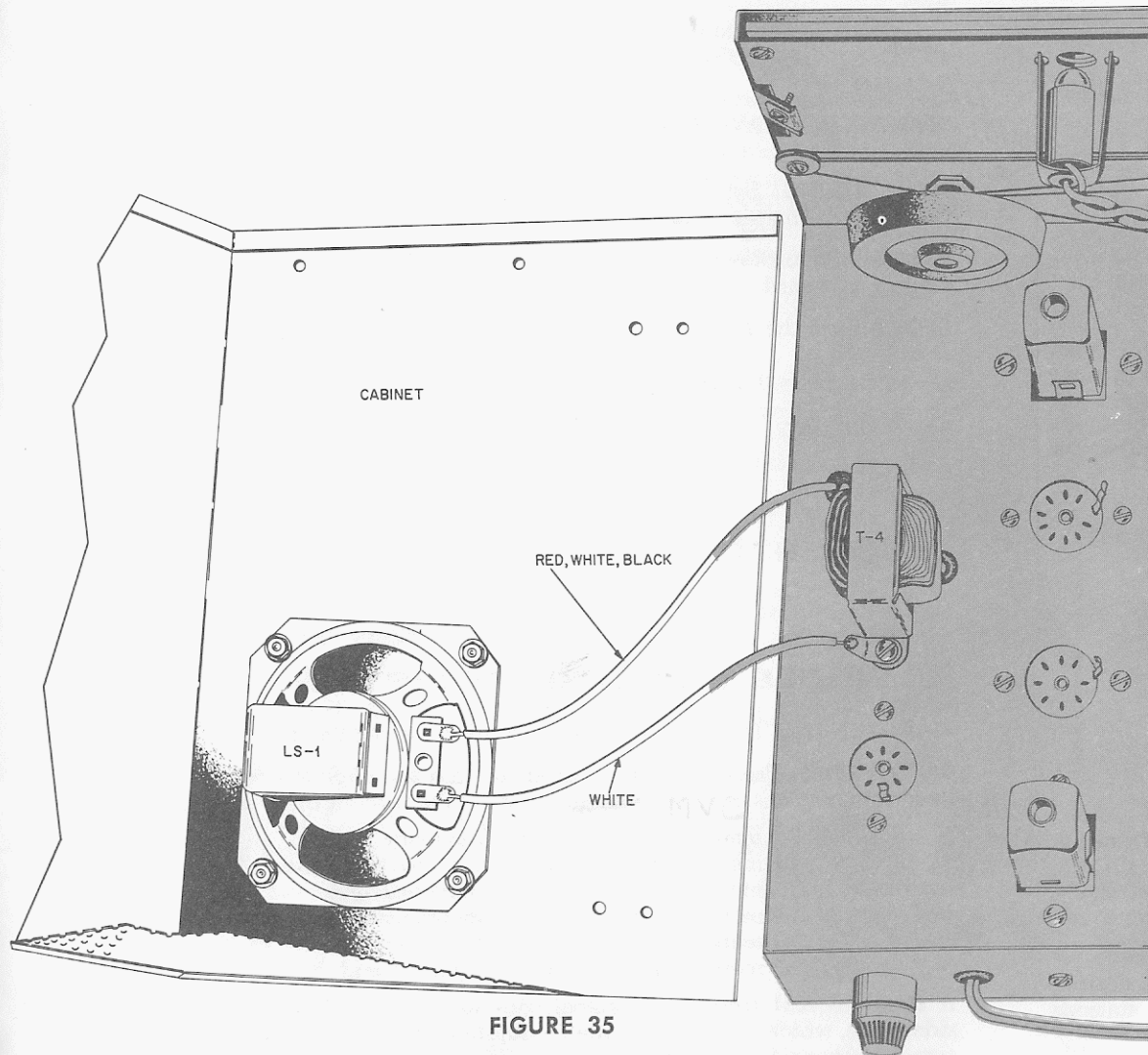

FIGURE 35



OPERATING INSTRUCTIONS

For the beginning Amateur operator or new short wave listener, we suggest that these instructions be followed closely. The extra care used in tuning will be well rewarded by bringing in many distant (DX) stations. The section on the best time for shortwave listening will also be very helpful.

CONTROL SETTINGS FOR STANDARD BROADCAST RECEPTION

STANDBY-MVC-AVC-CAL **AVC**
BFO **OFF**
BAND **A**
MAIN TUNING Turn dial to desired station. (Bandspread dial must be turned all the way to the right.)

BANDSPREAD: Not needed for local stations. Use for fine tuning for DX (distant) reception.

ANTENNA CONTROL: Adjust for strongest signal.

VOLUME: Adjust for desired volume.

CONTROL SETTINGS FOR SHORT WAVE LISTENING

Set controls same as for standard broadcasts above, except:

PHONE RECEPTION

BAND: Switch to B, C, D or E depending on frequency of station wanted.

BANDSPREAD: Set to SET MAIN TUNING.

MAIN TUNING: Turn dial to desired station. For Amateur phone reception, set the MAIN TUNING dial at the index mark for the desired Amateur band (80M-40M-20M-15M-10M-6M). Then tune in stations on the calibrated BANDSPREAD scale.

6-METER RECEPTION: Set the BANDSWITCH to band E. Set the MAIN TUNING dial to the 6-meter mark on band D. Tune in stations on the calibrated BANDSPREAD scale.

CW (CODE) RECEPTION

BFO **ON**
BAND Set to desired band
VOLUME full
STANDBY-MVC-AVC-CAL **MVC** (must always be in this position for CW reception)

MAIN TUNING: Set the MAIN TUNING dial at the index mark for the desired Amateur band.

BANDSPREAD: Slowly turn the BANDSPREAD dial until the desired station is heard.

BFO: Adjust the BFO control for the most pleasing note.

AMATEUR FREQUENCIES

| BAND SETTING | AMATEUR BAND | FREQUENCY RANGE |
|--------------|--------------|-----------------|
| B | 80M | 3.5 - 4.0mc |
| C | 40M | 7.0 - 7.3mc |
| C | 20M | 14.0 - 14.35mc |
| D | 15M | 21.0 - 21.45mc |
| D | 10M | 28 - 29.7mc |
| E | 6M | 50 - 54mc |

SINGLE SIDEBAND RECEPTION

MAIN TUNING: To index mark for desired Amateur band.

BANDSPREAD: Precedence has established the use of SSB transmitters in certain sections of each Amateur band. At the present time, these are:

| | |
|---------------|-------------------------|
| 80 meter band | high frequency end |
| 40 meter band | high and low freq. ends |
| 20 meter band | high frequency end |
| 15 meter band | high frequency end |
| 10 meter band | around 28.65mc |
| 6 meter band | low frequency end |

A standard AM transmitted signal consists of an RF carrier and two sidebands, which results from the modulation of the RF carrier. A SSB signal is characterized by the suppression of the carrier and one of the side bands. Thus the transmitted signal consists of one sideband only. It is fast becoming an increasingly popular method of transmission because it occupies less space in the radio spectrum and because there



is considerably less interference encountered among SSB signals during reception.

Reception of SSB signals requires the reinsertion of a carrier before the signal can be demodulated. This is done by the BFO.

Start by tuning to the portion of an Amateur band containing SSB signals. While tuning, turn the volume control up until loud, but unintelligible sounds are heard. It will sound something like duck quacking. Carefully tune the BFO control until intelligible sound is heard. The BFO control may be left at its setting while the BANDSPREAD dial is tuned to other stations. However, a change in sideband transmission from "lower" to "upper" sideband or vice-versa requires a readjustment of the BFO control.

REMOTE CONTROL

The two terminals marked REMOTE at the rear of the chassis can be connected to the transmit-receive switch of a transmitter, or to the contacts of a transmit-receive relay. By operating this switch or relay, the B+ voltage for the plates of the tubes can be turned on or off.

CRYSTAL CALIBRATOR (ACCESSORY)

The crystal calibrator is not supplied with this kit, but may be purchased as an accessory. It supplies a 100Kc signal for accurate frequency calibration of your receiver.

NOTE: DO NOT ADD THIS UNIT WHILE THE RECEIVER IS PLUGGED INTO A POWER OUTLET.

- Remove the cabinet from the chassis. Remove the bottom plate.
- Mount the Crystal Calibrator to the top of the chassis behind C-1 using two 4-40 x 3/8" screws, lockwashers and nuts.

There are four wires coming from the Crystal Calibrator. Feed these wires through the grommet containing the pilot lamp leads and connect as follows. (It is important that the leads be cut to the proper length to eliminate unnecessary slack.)

- Solder the red wire to terminal 3 of S-2.
- Solder the green wire to terminal 1 of TS-1.
- Solder the black wire to the solder lug attached to TS-2.
- Solder the brown wire to terminal 1 of TS-4.

- Leave the Crystal Calibrator switch in the ON position to control the Calibrator from the front panel of the receiver.
- Remount the bottom plate and cabinet.

You are now ready to use the Crystal Calibrator with your receiver. Simply turn the STANDBY-MVC-AVC-CAL SWITCH to CAL and calibrate your receiver as explained in the Crystal Calibrator manual.

INSTALLING AN ANTENNA

A good antenna will enable you to obtain maximum performance from your receiver. A half-wave dipole is recommended for top performance on a particular band of frequencies such as an amateur band. A single wire antenna of between 30 to 50 feet provides the best all-round reception for short-wave listening.

If you prefer to use a single-wire antenna, see Figure 36 for suggested installation. For the exact specifications of a half-wave dipole antenna, see the section on antennas in the "Amateur Handbook," published by the ARRL.

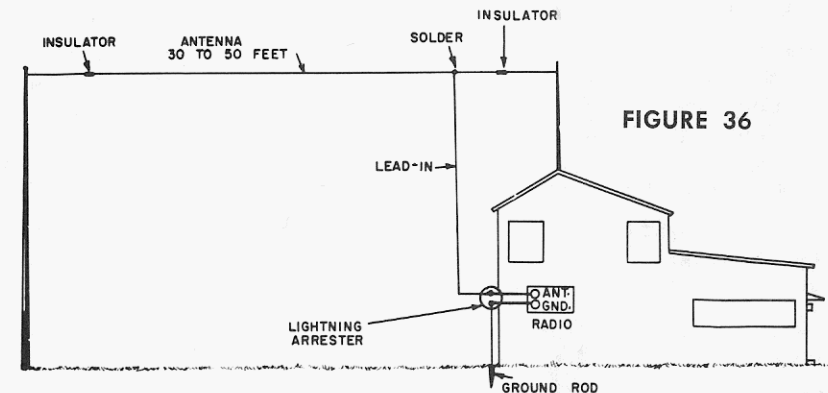

FIGURE 36

Regardless of the type antenna used, it is always advisable to mount the antenna as high as possible. Height adds to the effectiveness of the antenna.

HEADPHONES

If you wish to use headphones instead of the loudspeaker, simply plug the phones in the jack labeled PHONES. This automatically mutes the loudspeaker. The impedance of the headphones is not critical. Headphones with impedances ranging from 3Ω to 2000Ω will work satisfactorily.



WHEN TO LISTEN

Under normal atmospheric conditions, with patience and practice, it's possible to hear stations from all over the world in a single evening—at times even within a few minutes. All you need is your receiver, a good antenna, a knowledge of *where* and *when* to listen—plus persistence.

Short-wave radio transmitters include land communications stations, maritime stations, aeronautical stations, Amateur (Ham) stations, and broadcasting stations. Of these, the broadcasting and Amateur (Ham) stations are of most interest to the short-wave listener (SWL). However, there are many other "specialties" to listen to such as international radio telegraph or telephone point-to-point communications; shipping and coastal radio; plane and ground communications; weather station reports and time signals; special expeditions, and other unusual events.

By international agreement, each type of station is assigned certain bands for operations.

You'll find that the short-wave portions of the dial on your receiver are calibrated in megacycles. A megacycle is 1000 kilocycles (kc).

Short-wave stations operate in these megacycle bands—5.95 to 6.20mc; 7.0 to 7.3mc amateur band; 9.5 to 9.8mc; 11.7 to 12.0mc; 14.0 to 14.3mc amateur band; 15.10 to 15.45mc; 17.5 to 17.7mc and 28.0 to 29.7mc amateur band. Sometimes these bands are given in terms of meters (m)—such as the 49, 41, 50, 31, 25, 20, and 19 meter bands. Thus, **megacycles** refer to **frequency**; **meters** refer to **wavelength**.

Reception conditions on each of the short-wave broadcast bands vary a lot at different times of the day and night, and also at different seasons of the year. Experience will teach you when to listen on each band.

In general, for SWL's in North America, the best reception on each of these bands during the fall and spring months should be:

The 6mc band—evening for Latin America and Europe.

The 7mc bands—late afternoon and evening for Europe; evening and early morning for Amateur stations.

The 9mc band—morning (6 to 8 a.m. your local time) for Asia and Australia; afternoon for Europe and Africa; evening for Europe and Latin America.

The 11mc band—morning (6 to 9 a.m. your local time) for Asia and Australia; afternoon for Europe and Africa; evening for Latin America.

The 14mc band—late morning and afternoon for Amateur stations.

The 15mc band—morning and afternoon for Europe and North America; evening for North and South America.

The 29mc band—daylight hours for Amateur stations.

During the winter months, the best bands for evening reception are lower than during the fall and spring. For instance, the 9mc band becomes poor for reception from Europe during the evening hours, and the 6mc band becomes the best band for European reception. However, the 29mc Amateur band is best during winter months, especially at the peak of the sunspot cycle.

In the summer months, the best evening reception shifts to the higher bands. Evening reception from Europe becomes good in the 11mc band, although the 9mc band remains good for reception from that area.

Year-around DX (Distant reception) bands are the 9mc and 11mc bands, although consideration there must be given to receiving different parts of the world best in summer or winter.

The expected reception just outlined is for normal conditions. The factors which affect long-distance radio transmissions vary from day to day. On some days, for instance, reception will be quite good, but at times, generally for periods of several consecutive days, transmission conditions will be "disturbed" and only the more powerful stations can be heard.

Here's a special caution: Short-wave broadcasting stations often change their schedules and/or frequencies with little or no prior notice. Always be on the alert for announcements of such changes.

HOW IT WORKS

BAND SELECTION. By rotating band switch S-1A (see block diagram), one of the five antenna coils is switched into the antenna circuit which has the ability to accept a given band of frequencies and reject all others.

TUNING. Tuning capacitor C-1A is wired in parallel with the switched antenna coil, forming a parallel resonant circuit. When this capacitor is set for some specific value, it tunes in a signal corresponding in frequency to the pointer setting on the main tuning dial. The remaining frequencies in the band are rejected.

BANDSPREAD. The bandspread capacitor C-2A is connected in parallel with the main tuning capacitor. When rotated, this capacitor changes

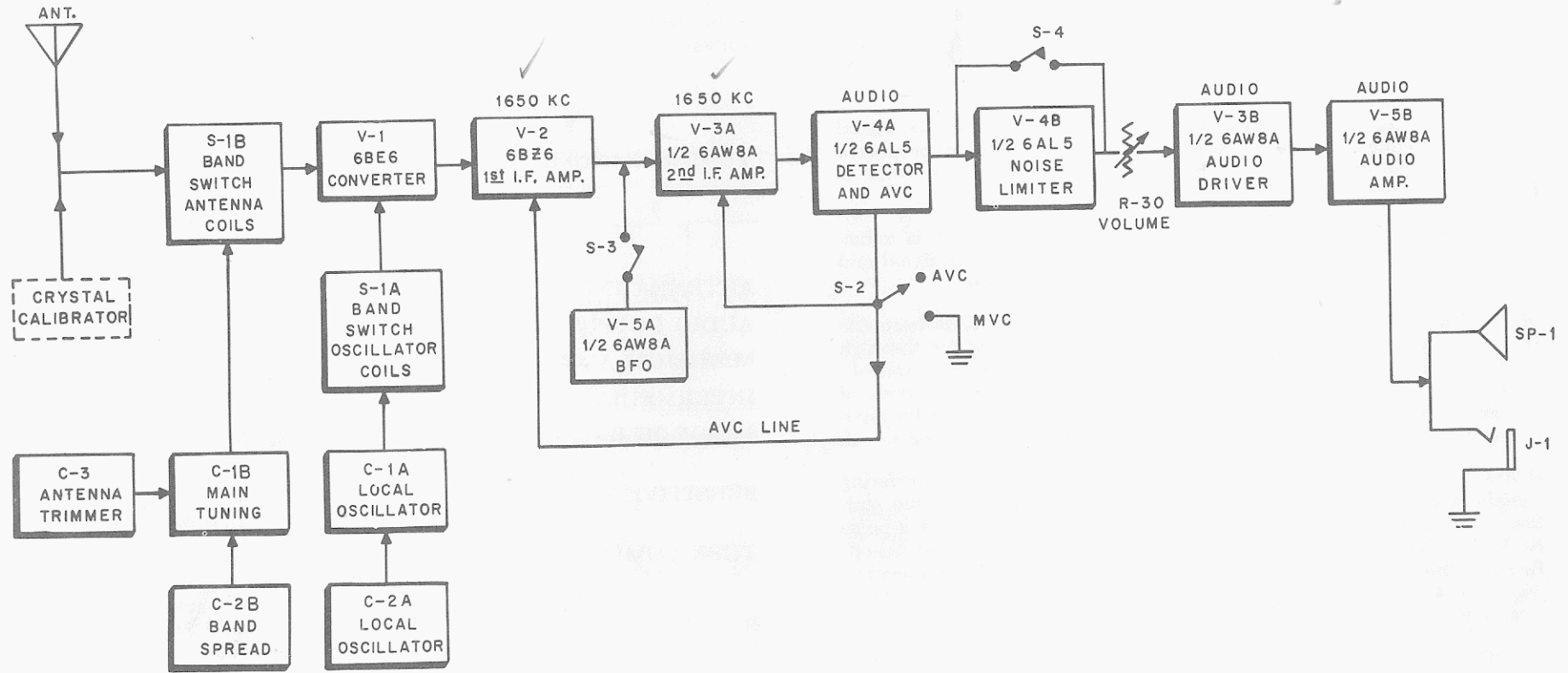



HOW IT WORKS

the resonant point of the receiver slightly to either side of the setting on the main tuning dial.

ANTENNA TRIMMER. Capacitor C-3 is in parallel with the main tuning and bandspread capacitors. When rotated, this capacitor more accurately tunes the antenna circuit to the desired signal frequency, resulting in a louder and more readable signal.

LOCAL OSCILLATOR. The local oscillator is composed of the five oscillator (one for each band) coils and capacitors C-1B and C-2B. This oscillator generates a signal whose frequency is always 1650kc above or below the RF signal being received.

CONVERTER. Tube V-1 heterodynes or mixes the selected RF signal from the antenna with the signal from the local oscillator to produce a third signal called the IF (intermediate frequency) whose value is 1650kc.

IF AMPLIFIERS. The IF signal, coming from the plate of V-1, is inductively coupled to the grid of V-2 by T-1. V-2 amplifies this signal and passes it on to V-3A for the second stage of amplification.

DETECTOR and AVC. V-4A separates the audio component from the IF signal by furnishing a low impedance path to ground for the high frequency portion. It also acts as an AVC (automatic volume control) by feeding a portion of the detected IF signal back to the grids of V-2 and V-3A. This feedback helps keep the volume constant by regulating the amount of amplification these tubes give the incoming signal.

NOISE LIMITER. V-4B will remove or reduce in amplitude interfering signals of high amplitude and short duration, such as automobile ignition noises and disturbances from household appliances. When a noise peak of sufficient amplitude reaches V-4B, the tube is driven to cut-off. Because the tube has momentarily ceased conducting, limiting occurs. Switch S-4 allows the signal to bypass this circuit when the noise limiter is not needed.

AUDIO AMPLIFIERS. The detected portion of the IF signal (audio) goes through R-50 (volume control) and onto the grid of V-3B, audio driver. The signal is amplified and passed onto the grid of V-5B, audio amplifier, where it receives sufficient amplification to drive loudspeaker SP-1 or a pair of headphones plugged into J-1.

BFO. L-11, C-14 and V-5A form the beat frequency oscillator. The BFO generates a signal whose frequency is equal to the IF (1650kc). By rotating C-14, the frequency of the BFO can be varied about 3kc. When the BFO signal is heterodyned with the IF signal an audible

tone can be heard in the loudspeaker. This tone is the difference between the IF and BFO frequencies. The heterodyning of these signals is accomplished at V-3A. Switch S-3 removes the BFO from the circuit when not needed.

POWER SUPPLY. The built-in power supply is operated from 117 volts AC 50/60 cycle house current. It supplies the DC and filament voltages needed to operate the tubes. The center tap of power transformer T-5 is brought out to terminal strip TS-2 for remote control of the B+ voltage.

SPECIFICATIONS

| | | |
|-------------------------|---|----------------|
| TUNING RANGES | BAND A | .53mc to 1.9mc |
| | BAND B | 1.8mc to 6.3mc |
| | BAND C | 6mc to 14.5mc |
| | BAND D | 11.5mc to 33mc |
| | BAND E | 47mc to 54mc |
| ANTENNA INPUT IMPEDANCE | 52Ω | |
| AUDIO OUTPUT IMPEDANCE | 3.2Ω | |
| MAXIMUM AUDIO OUTPUT | 1 watt | |
| INTERMEDIATE FREQUENCY | 1650kc | |
| IMAGE REJECTION | From 42 db at 80M to 14 db at 6M | |
| SENSITIVITY | 80M-4μv; 40M-6μv; 20M-8μv; 15M-7μv; 10M-6μv; 6M-10μv. | |
| TUBE COMPLEMENT | 6BE6 (converter and oscillator) 6BZ6 (1st IF amplifier) 6AW8 (2nd IF amplifier) 6AL5 (detector and noise limiter) 6AW8 (audio output and BFO) EZ90 (rectifier) | |
| POWER CONSUMPTION | 60 watts, 117v, 60 cycle | |
| DIMENSIONS | 11" deep, 14¼" wide, 8⅝" high. | |
| NET WEIGHT | 19 lbs. | |



The proper operating voltages are found on the circuit diagram. The proper resistances are found in the resistance chart. Never measure resistances with the receiver turned on.

RESISTANCE CHART

| TUBE | PIN | | | | | | | | |
|------|---------|---------|-------|---|-------|------|---------|------|-------|
| | 1 | 2 | 3 | 4 | 5 | 6 | 7 | 8 | 9 |
| V-1 | 22K | 0 | 0 | 0 | 2.7K* | 10K* | 0 | | |
| V-2 | 1.7 Meg | 180Ω | 0 | 0 | 1.8K* | 22K* | 0 | | |
| V-3 | 2.7K | 100K | 220K* | 0 | 0 | 180Ω | 1.7 Meg | 47K* | 1.3K* |
| V-4 | 0 | 2.2 Meg | 0 | 0 | 200K | N.C. | 620K | | |
| V-5 | ∞ | 4.7K | 320K* | 0 | 0 | 150Ω | 470K | 10K* | 600Ω* |
| V-6 | 145Ω | N.C. | 0 | 0 | N.C. | 145Ω | 330Ω* | | |

All measurements made with reference to chassis ground unless otherwise specified.
*Measured from terminal 2 of C-36.

Set controls as follows for resistance measurements:
Band switch to A—BFO OFF—Volume open—AVC—Noise limiter OFF

| TROUBLE | POSSIBLE CAUSE | SERVICE PROCEDURE |
|---|--|--|
| Receiver dead | Defective tube(s) | Replace defective tubes. |
| | Tubes in wrong sockets or not seated. Line cord not in AC outlet | Visual inspection |
| | Fuse open | Check fuse. Look for power supply shorts. |
| | Low B+ voltages | Check C-36 |
| Poor sensitivity on all bands | Defective tubes | Check tubes |
| | IF stages misaligned | Realign. |
| | AVC line is grounded | Check S-2 wiring. |
| Output distorts on strong AM signals when receiver is in AVC position | | |
| HUM | Open filter capacitor. Shorted tube. Short circuit which draws excessive current | C-36 defective. Test tubes. Look for wrong connections and uninsulated wires shorting. |
| | Bad 6AW8A | Replace tube. |
| Beat frequency oscillator does not function | L-11 not properly adjusted | Readjust L-11. |



CAPACITORS

| Symbol Number | Description | Part Number |
|---------------|---|-------------|
| C-1 | Main tuning capacitor | 282021 |
| C-2 | Bandsread | 282022 |
| C-3 | Antenna trimmer | 281022 |
| C-4 | 75 μmf , 5% silver mica | 264759 |
| C-5 | 20 μmf , disc | 296014 |
| C-6 | 3-50 μmf , trimmer | 283005 |
| C-7 | 500 μmf , 5% silver mica | 294008 |
| C-8 | .001 μf , disc | 276016 |
| C-9 | .05 μf , disc | 275506 |
| C-10 | .0047 μf , disc | 276477 |
| C-11 | .05 μf , disc | 275506 |
| C-12 | .02 μf , disc | 276025 |
| C-13 | 6.2 μmf , 5% disc | 296033 |
| C-14 | BFO adjustment | 281023 |
| C-15 | 100 μmf , silver mica | 266017 |
| C-16 | .01 μf , disc | 276015 |
| C-17 | .01 μf , disc | 276015 |
| C-18 | 1000 μmf , silver mica | 266014 |
| C-19 | 150 μmf , disc | 276158 |
| C-20 | 10 μmf , disc | 276018 |
| C-23 | .05 μf , disc | 275506 |
| C-24 | 470 μmf , disc | 276478 |
| C-25 | 50 μf , electrolytic 10v | 221500 |
| C-27 | .01 μf , disc | 276015 |
| C-28 | .001 μf , 5% disc | 276016 |
| C-29 | .0047 μf , 5% disc | 276477 |
| C-30 | 470 μmf , 5% disc | 276478 |
| C-31 | 50 μf , electrolytic 10v | 221500 |
| C-32 | 100 μmf , disc | 276017 |
| C-33 | .01 μf , disc | 276015 |
| C-34 | .01 μf , disc | 276015 |
| C-35 | .01 μf , disc | 276015 |
| C-36 | 40-40-40-40 μf , electrolytic 350v | 236404 |
| C-37 | .001 μf , disc | 276016 |
| C-39 | .0047 μf , disc | 276477 |
| C-40 | .0047 μf , disc | 276477 |
| C-41 | 620 μmf , 5% silver mica | 264628 |
| C-42 | .01 μf , disc | 276015 |
| C-43 | .01 μf , disc | 276015 |
| C-44 | .01 μf , disc | 276015 |

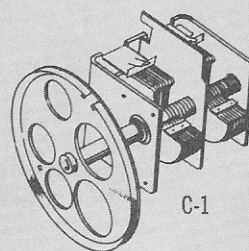

C-1

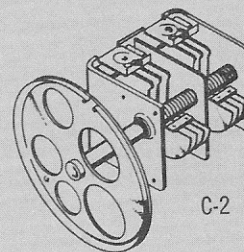

C-2

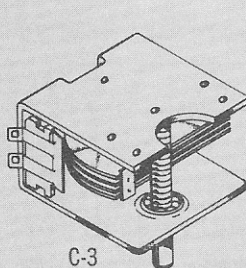

C-3

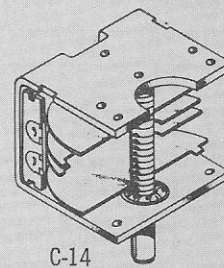

C-14

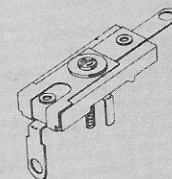

C-6

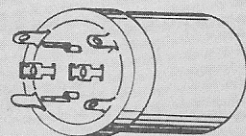

C-36

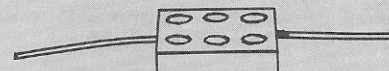

C-4, C-7, C-41

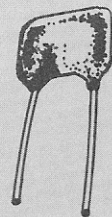

C-15, C-18

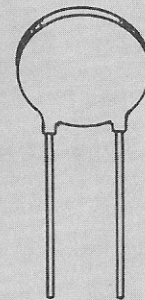

DISC

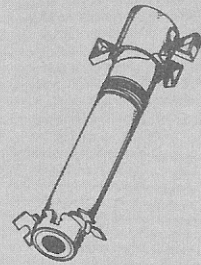

L-1 to L-10

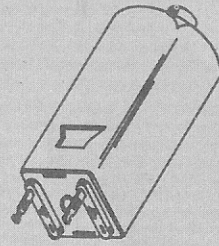

L-11

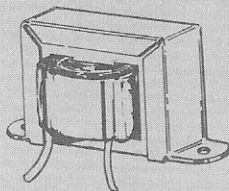

L-12



1/2 WATT RESISTOR



1 WATT RESISTOR

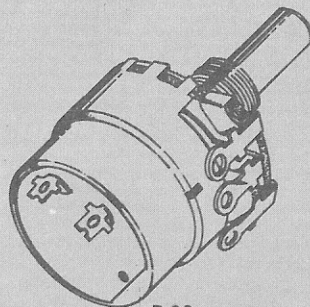

R-30

COILS

| Symbol Number | Description | Part Number |
|---------------|------------------------|-------------|
| L-1 | band A Antenna coil | 162033 |
| L-2 | band B Antenna coil | 162034 ✓ |
| L-3 | band C Antenna coil | 162035 |
| L-4 | band D Antenna coil | 162036 |
| L-5 | band E Antenna coil | 162037 |
| L-6 | band A Oscillator coil | 162038 |
| L-7 | band B Oscillator coil | 162039 |
| L-8 | band C Oscillator coil | 162040 |
| L-9 | band D Oscillator coil | 162041 |
| L-10 | band E Oscillator coil | 162042 |
| L-11 | BFO coil | 162032 |
| L-12 | Choke coil | 140003 |

RESISTORS

| | | |
|------|---------------------------|--------|
| R-1 | 22K | 301223 |
| R-2 | 12K, 2 watt | 307123 |
| R-3 | 2.7K | 301272 |
| R-4 | 100K | 301104 |
| R-5 | 180Ω | 301181 |
| R-6 | 22K | 301223 |
| R-7 | 47K | 301473 |
| R-8 | 39K | 301393 |
| R-9 | 100K | 301104 |
| R-10 | 220K | 301224 |
| R-11 | 1.8K | 301182 |
| R-12 | 100K | 301104 |
| R-13 | 4.7 meg | 301475 |
| R-15 | 2.7K | 301272 |
| R-16 | 220K | 301224 |
| R-17 | 1 meg | 301105 |
| R-18 | 180Ω | 301181 |
| R-19 | 47K | 301473 |
| R-20 | 1.3K, 5% | 302132 |
| R-21 | 2.2 meg | 301225 |
| R-22 | 47K | 301473 |
| R-23 | 470K | 301474 |
| R-24 | 150Ω | 301151 |
| R-25 | 10K, 1 watt | 304103 |
| R-26 | 100K | 301104 |
| R-27 | 470K | 301474 |
| R-28 | 470K | 301474 |
| R-29 | 470K | 301474 |
| R-30 | 1 meg control with switch | 390005 |
| R-31 | 33Ω | 301330 |
| R-32 | 1 meg | 301105 |
| R-33 | 100Ω, 1 watt | 304101 |



PARTS LIST

SWITCHES

| Symbol Number | Description | Part Number |
|---------------|----------------------------------|-------------|
| S-1 | band switch and bracket..... | 040084 |
| S-2 | STANDBY-MVC-AVC-CAL switch | 432137 |
| S-3 | BFO | 431003 |
| S-4 | noise limiter | 431003 |

TERMINAL STRIPS

| | | |
|------|------------------------|--------|
| TS-1 | 2-screw terminal | 441201 |
| TS-2 | 2-screw terminal | 441201 |
| TS-3 | 3-terminal | 440301 |
| TS-4 | 4-terminal | 440401 |
| TS-5 | 4-terminal | 440401 |
| TS-6 | 3-terminal | 440301 |
| TS-7 | 6-terminal | 440602 |
| TS-8 | 6-terminal | 440601 |
| TS-9 | 2-terminal | 440202 |

TRANSFORMERS

| | | |
|-----|--------------------------|--------|
| T-1 | IF transformer | 122216 |
| T-2 | IF transformer | 122217 |
| T-3 | IF transformer | 122218 |
| T-4 | Output transformer | 102218 |
| T-5 | Power transformer | 101325 |

TUBES

| | | |
|-----|----------------|--------|
| V-1 | 6BE6 | 610045 |
| V-2 | 6BZ6 | 610050 |
| V-3 | 6AW8A | 611026 |
| V-4 | 6AL5 | 611005 |
| V-5 | 6AW8A | 611026 |
| V-6 | EZ90/6X4 | 610023 |

MISCELLANEOUS

| Description | Quantity | Part Number |
|--|----------|-------------|
| Bracket, for bandspread and main tuning capacitors.. | 2..... | 470283 |
| Bracket, for antenna coils | 1..... | 470285 |
| Bracket, for oscillator coils | 1..... | 470286 |
| Bracket, shield | 1..... | 470284 |

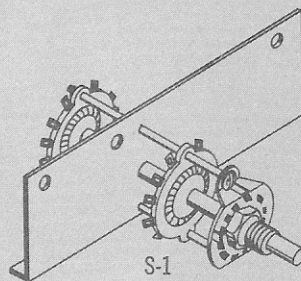

S-1

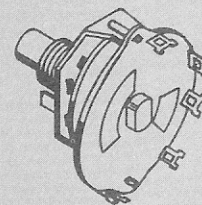

S-2

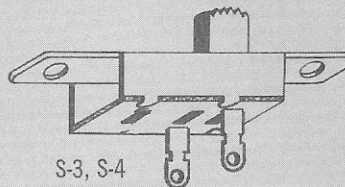

S-3, S-4



TS-1, TS-2

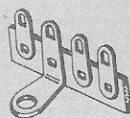

TS-4, TS-5

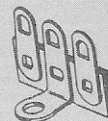

TS-3, TS-6

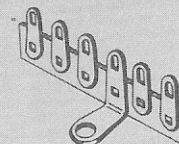

TS-7

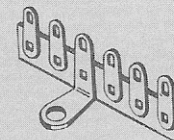

TS-8



TS-9

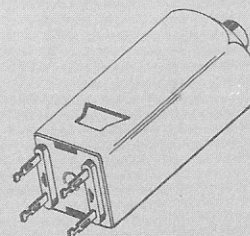

T-1, T-2, T-3

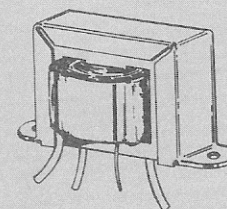

T-4



MISCELLANEOUS (Continued)

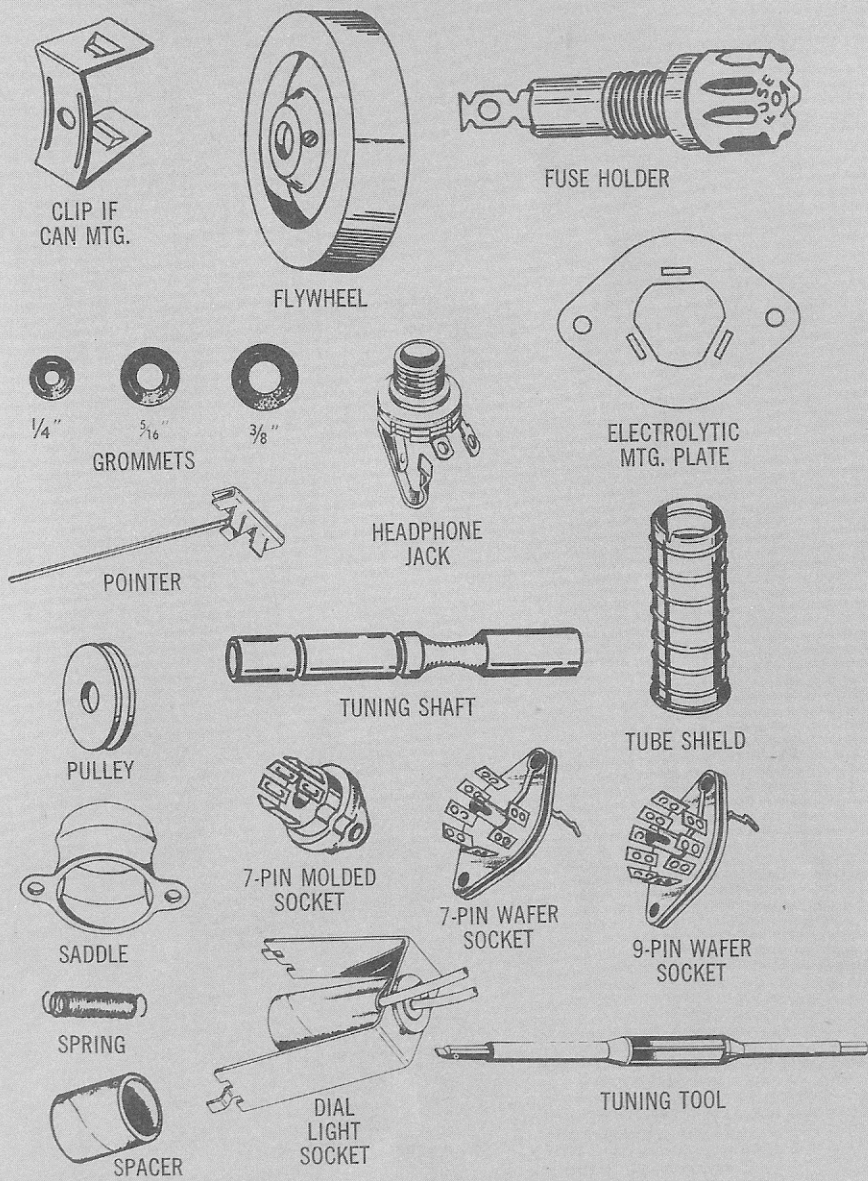

| Description | Quantity | Part Number |
|--------------------------------------|----------|-------------|
| Bracket, for C-3 | 1 | 470289 |
| Bracket, trimmer | 1 | 470288 |
| Cabinet | 1 | 700067 |
| Chassis | 1 | 461355 |
| Clip, IF can | 4 | 532008 |
| Dial light bulb, #51 | 2 | 640007 |
| Dial string, 6' | 2 | 860017 |
| Flywheel | 2 | 480004 |
| Foot, rubber | 4 | 831001 |
| Fuse, 1 amp | 1 | 491001 |
| Fuse holder | 1 | 492200 |
| Grommet, 1/4" | 8 | 830001 |
| Grommet, 5/16" | 6 | 830100 |
| Grommet, 3/8" | 1 | 830200 |
| Jack, headphone | 1 | 502228 |
| Knob, large | 2 | 761400 |
| Knob, large with white dot | 2 | 761304 |
| Knob, small with white dot | 3 | 761004 |
| Manual | 1 | 750265 |
| Panel, front | 1 | 462247 |
| Panel, plexiglass | 1 | 462704 |
| Panel, sub | 1 | 470287 |
| Plate, bottom | 1 | 463310 |
| Plate, electrolytic mounting | 1 | 501542 |
| Pointer, red | 1 | 470291 |
| Pointer, green | 1 | 470293 |
| Pulley, plastic | 4 | 880014 |
| Rubber pad | 1 | 840011 |
| Shaft, tuning | 2 | 470281 |
| Shield braid, 2 1/2" | 2 | 804133 |
| Shield, for V-1 | 1 | 510006 |
| Shield, ribbed for V-2, 2" | 1 | 510002 |
| Shield, ribbed for V-4 | 1 | 510012 |
| Shield, 9-pin tube, ribbed | 2 | 510003 |
| Shield, saddle | 1 | 511005 |
| Socket, 7-pin molded | 1 | 501170 |
| Socket, 7-pin wafer | 1 | 501072 |
| Socket, 7-pin wafer with shield clip | 2 | 501073 |
| Socket, 9-pin wafer with shield clip | 2 | 501093 |
| Socket, dial light | 2 | 501731 |
| Spacer, paper | 2 | 850063 |
| Speaker, 3 1/2" | 1 | 730022 |
| Spring | 2 | 470076 |
| Tuning tool | 1 | 957007 |



PARTS LIST

HARDWARE

| Description | Quantity | Part Number |
|---|----------|-------------|
| Bushing $\frac{3}{8}$ " | 2 | 470075 |
| Clip nut | 2 | 572220 |
| "C" Washer | 4 | 585002 |
| Eyelets, small diameter | 4 | 551008 |
| Eyelets, large diameter | 5 | 551009 |
| Grounding lug | 1 | 553001 |
| Lockwasher, #4 | 44 | 582200 |
| Lockwasher, #6 | 6 | 582300 |
| Lockwasher, #8 | 11 | 582400 |
| Lockwasher, $\frac{3}{8}$ " | 1 | 572700 |
| Solder lug, #6 | 20 | 553005 |
| Solder lug, #8 | 1 | 553002 |
| Screw, 3-48 x $\frac{1}{4}$ " | 2 | 560112 |
| Screw, 3-48 x $\frac{5}{16}$ " | 2 | 560116 |
| Screw, 3-48 x $\frac{3}{4}$ " | 1 | 560117 |
| Screw, 4-40 x $\frac{5}{16}$ " | 2 | 560223 |
| Screw, 4-40 x $\frac{3}{8}$ " | 42 | 560224 |
| Screw, 4-40 x $\frac{3}{8}$ ", black | 4 | 569224 |
| Screw, 6-32 x $\frac{1}{8}$ " | 3 | 560340 |
| Screw, 6-32 x $\frac{3}{16}$ ", flat head | 6 | 563347 |
| Screw, 6-32 x $\frac{5}{16}$ ", flat head | 4 | 563373 |
| Screw, 8-32 x $\frac{1}{4}$ " | 8 | 563442 |
| Screw, self-tapping, #4 x $\frac{1}{4}$ " | 8 | 569292 |
| Screw, self-tapping, #6 x $\frac{3}{8}$ " | 4 | 563394 |
| Set screw | 2 | 569001 |
| Nut, 3-48 | 5 | 570110 |
| Nut, 4-40 | 42 | 570220 |
| Nut, 6-32 | 4 | 570340 |
| Nut, 8-32 | 4 | 570440 |
| Nut, $\frac{3}{8}$ " | 6 | 570840 |
| Washer, fiber | 4 | 590200 |
| Washer, flat metal, #4 | 4 | 580200 |
| Washer, flat metal, $\frac{3}{8}$ " | 6 | 580702 |



BUSHING



CLIP NUT



EYELETS



'C' WASHER

HARDWARE (ACTUAL SIZE)

3-48

4-40

6-32

8-32

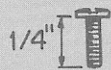

1/4"

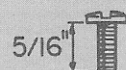

5/16"

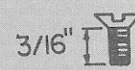

3/16"



1/4"

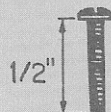

1/2"

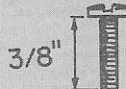

3/8"

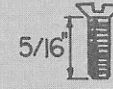

5/16"

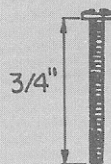

3/4"

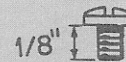

1/8"



#4 SELF-TAPPING



#6 SELF-TAPPING



#4 FLAT WASHER



$\frac{3}{8}$ " FLAT WASHER



#6 SOLDER LUG



GROUNDING LUG



#8 SOLDER LUG



$\frac{3}{8}$ " NUT



$\frac{3}{8}$ " LOCKWASHER



SETScrew

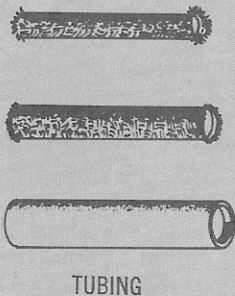
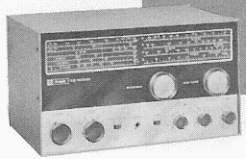

WIRE, SOLDER AND TUBING

| Description | Quantity | Part Number |
|---------------------------------------|----------|-------------|
| Bare wire, heavy, 95" | 1 | 806495 |
| Bare wire, thin, 12" | 1 | 806012 |
| Cable, 2-conductor shielded, 26" | 1 | 803075 |
| Cable, single-conductor shielded, 36" | 2 | 803071 |
| Line cord | 1 | 802001 |
| Solder, 12' | 1 | 930005 |
| Tubing, black, 20" | 1 | 812019 |
| Tubing, yellow, 8" | 4 | 812021 |
| Tubing, red, 7" | 1 | 812007 |
| Wire, 2", red | 10 | 801002 |
| Wire, 3", orange | 10 | 801003 |
| Wire, 4", yellow | 6 | 801004 |
| Wire, 5", green | 6 | 801005 |
| Wire, 6", blue | 6 | 801006 |
| Wire, 7", violet | 1 | 801007 |
| Wire, 9", white | 2 | 801009 |
| Wire, 20", white-red-black | 1 | 801020 |

TOOLS NEEDED FOR CONSTRUCTION

| Stock Number | Description | Price* |
|--------------|---------------------------------|---------|
| 46 N 852 | Soldering iron, pencil type | \$ 5.78 |
| 50 N 132 | Longnose pliers, 6" | 2.10 |
| 50 N 133 | Diagonal cutters, 5" | 1.84 |
| 45 N 378 | Screwdriver, 6" with 1/4" blade | .64 |

ACCESSORIES YOU MAY WANT

| Stock Number | Description | Price |
|--------------|-----------------------|----------|
| 83 Y 256 | Crystal calibrator | \$10.95 |
| 47 W 516 | Coaxial cable RG 58/U | .085 ft. |
| 59 J 141 | Headphones | 2.00 |

*Subject to change.



100-kc Crystal Calibrator kit for the R-55 Receiver. Provides marker every 100 kc up to 54 mc. Has trimmer for zero beating with WWV. Obtains power from R-55 Receiver.



FREE INFORMATION SERVICE

First, write a letter to us if your wired kit does not operate properly. Address KNIGHT-KIT Dept. at Allied Radio. Give the stock number of the kit, date of purchase and describe the problem. In a great many cases our technicians can determine corrective steps from the information in your letter. This free information service may save you the expense and inconvenience of returning the kit for repairs.

Should it appear that work in our shop is necessary, we will send you a pre-addressed label and specific packing instructions for your kit.

SPECIAL INSPECTION SERVICE

You may return this wired KNIGHT-KIT for inspection and repair within one year after purchase for a special service charge of \$7.50. An additional charge will be made for any parts damaged in construction or for parts beyond the EIA 90-day warranty period. Service charges for kits returned after the one year period will be based on the length of time needed to repair the unit plus the cost of any parts required.

PLEASE NOTE: Kits soldered with acid core solder, paste flux, or with irons cleaned on a sal ammoniac block are not eligible for

repair or service because they have been permanently damaged by the acid flux.

PACKING INSTRUCTIONS

If you return this kit, pack it well. Do NOT use the original carton — it is too small for the assembled kit. To prevent damage in shipment, use a carton large enough so that cushioning material can be placed around the instrument. Cushion it well and tightly. Mark it: **FRAGILE—DELICATE ELECTRONIC EQUIPMENT.**

We recommend that this equipment be shipped **ONLY** by Railway Express, if at all possible, to forestall damage in shipment. Send the kit prepaid and insured. We will return the repaired kit to you C.O.D. as soon as repairs are completed. If you wish to save C.O.D. fees, your advance remittance may be enclosed for standard repair charges plus transportation costs. Any excess remittance will be refunded.

IF YOUR KIT ARRIVED DAMAGED

If your kit was damaged in a parcel post shipment, please write us at once, describing the condition in which the shipment was received. If your kit was part of a Railway Express shipment that was damaged in transit, please notify the local Railway Express agent at once and then write us.

KNIGHT-KIT GUARANTEE

Allied extends these firm guarantees on KNIGHT-KITS; all KNIGHT-KITS are sold with an exclusive money-back guarantee to meet or exceed published specifications and to perform exactly as specified or we refund your money.

In addition, we guarantee that only premium-quality components are selected for use in KNIGHT-KITS. Every KNIGHT-KIT component is fully warranted against defects in material and workmanship for a period of 90 days from date of original purchase. Should replacement parts be required under this warranty, notify us promptly, including sufficient details to identify the required parts. Parts will be shipped without charge. We reserve the right to request the return of defective parts.

6BE6
CONVERTER
212V

6BZ6
1ST IF AMPLIFIER
195V

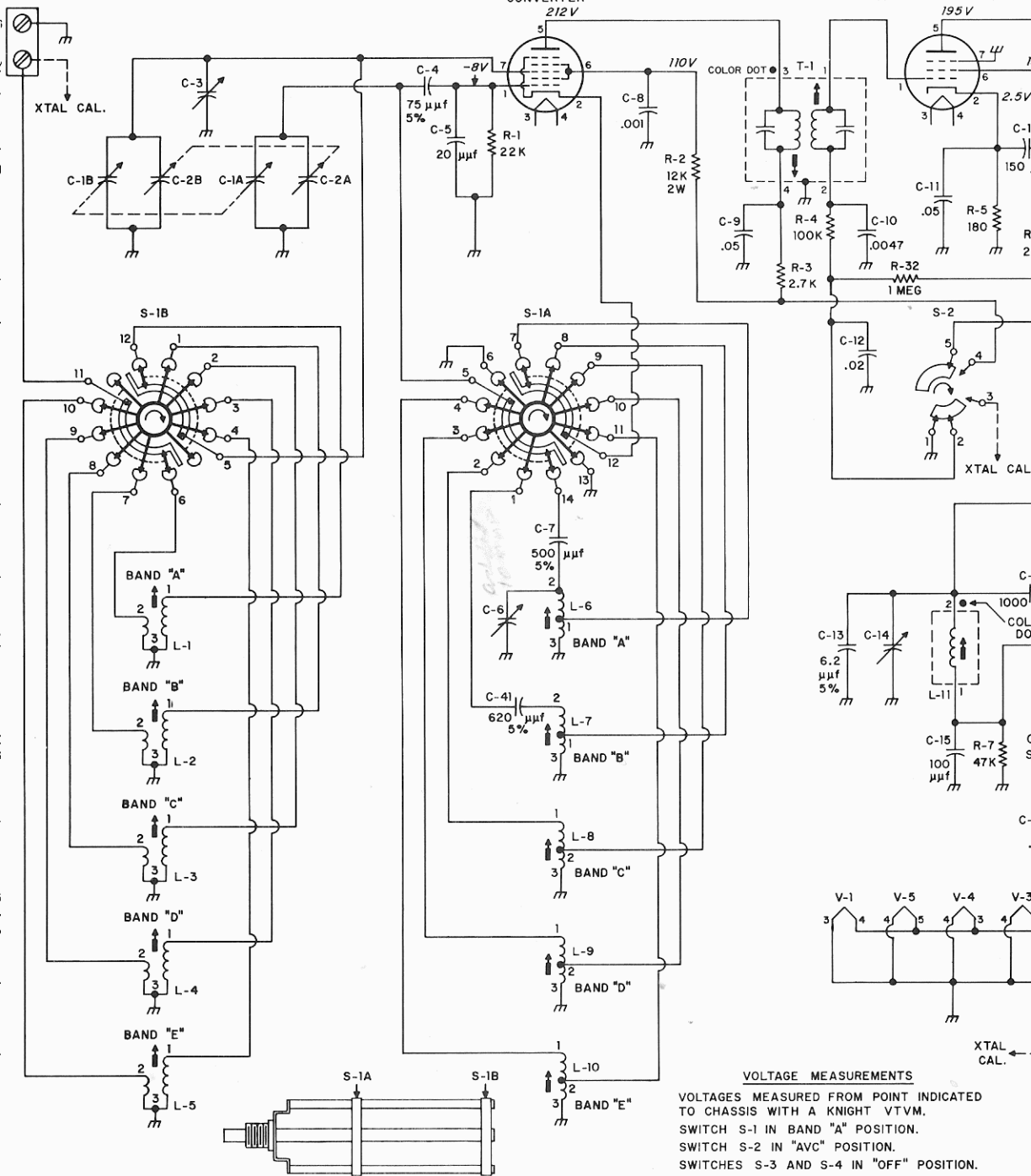

BAND SELECTOR SWITCH S-1

VOLTAGE MEASUREMENTS

VOLTAGES MEASURED FROM POINT INDICATED TO CHASSIS WITH A KNIGHT VTVM.
 SWITCH S-1 IN BAND "A" POSITION.
 SWITCH S-2 IN "AVC" POSITION.
 SWITCHES S-3 AND S-4 IN "OFF" POSITION.
 NO SIGNAL INPUT.
 LINE VOLTAGE = 117 V. 60 CYCLES AC.
 TOLERANCE ± 20%.

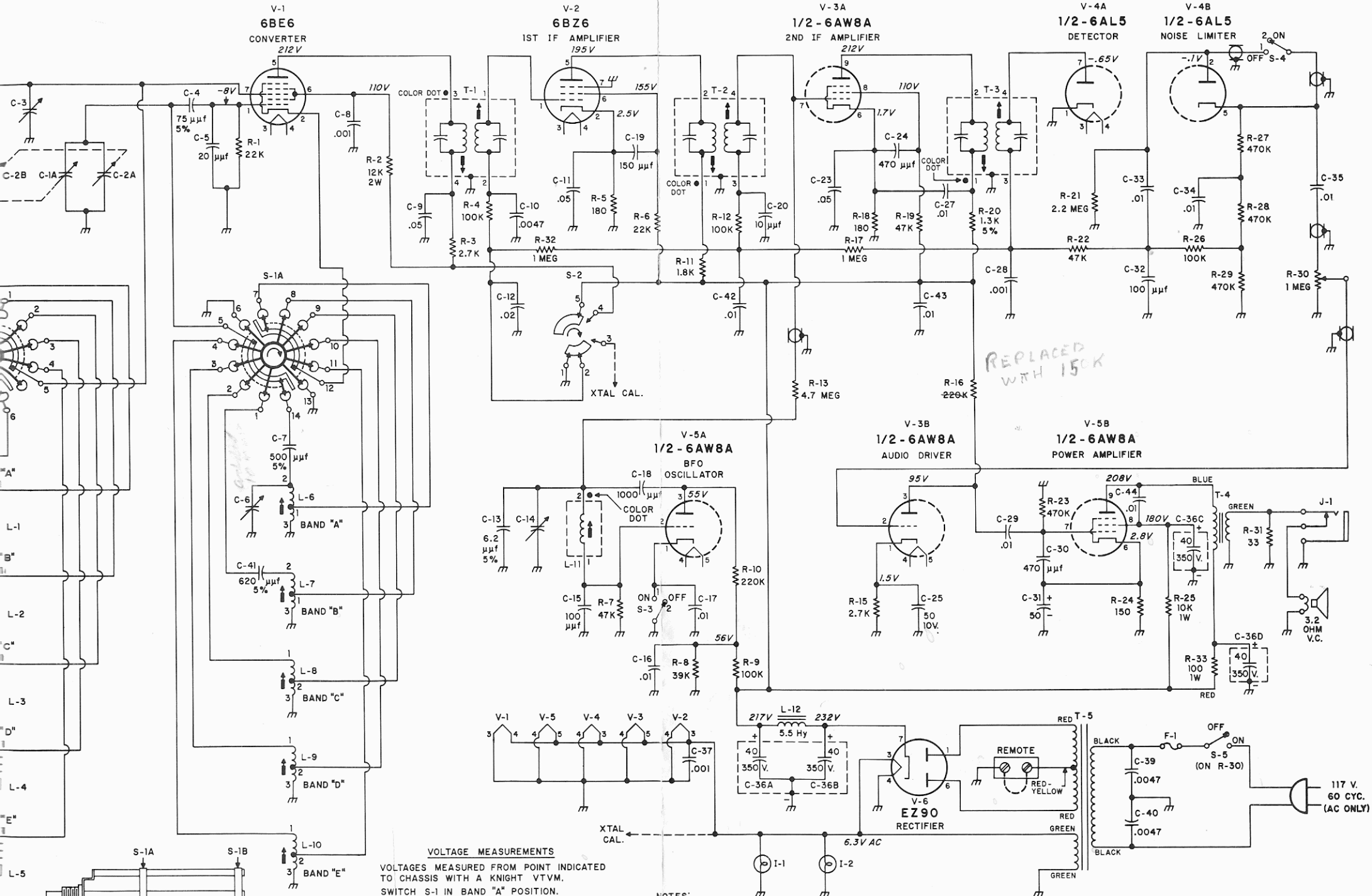

REPLACED WITH 150K

VOLTAGE MEASUREMENTS

VOLTAGES MEASURED FROM POINT INDICATED TO CHASSIS WITH A KNIGHT VTVM.
 SWITCH S-1 IN BAND "A" POSITION.
 SWITCH S-2 IN "AVC" POSITION.
 SWITCHES S-3 AND S-4 IN "OFF" POSITION.
 NO SIGNAL INPUT.
 LINE VOLTAGE = 117V. 60 CYCLES AC.
 TOLERANCE ±20%.

NOTES:

RESISTORS INDICATED IN OHMS.
 K=1,000 OHMS.
 MEG=1,000,000 OHMS.

CAPACITORS INDICATED IN MICROFARADS
 UNLESS OTHERWISE SPECIFIED.
 ⚡ = CHASSIS GROUND.

BAND SELECTOR SWITCH S-1

117 V.
60 CYC.
(AC ONLY)



KNIGHT-KITS ARE YOUR BEST BUY THE FINEST ELECTRONIC EQUIPMENT IN KIT FORM. CREATIVE ENGINEERING AND USE OF PREMIUM QUALITY PARTS ASSURE SUPERIOR PERFORMANCE. THAT'S WHY KNIGHT-KITS ARE SOLD WITH THIS EXCLUSIVE GUARANTEE: *EVERY KNIGHT-KIT MUST MEET PUBLISHED SPECIFICATIONS OR WE REFUND YOUR MONEY.*

KNIGHT-KITS ARE "CONVENIENCE ENGINEERED" RESISTORS ARE CARD MOUNTED AND IDENTIFIED. WIRE IS PRECUT. SMALL PARTS ARE PACKAGED IN SEE-THROUGH PLASTIC BAGS. DETAILS SUCH AS THESE AND STEP-BY-STEP INSTRUCTION MANUALS MAKE KNIGHT-KITS EASIEST TO BUILD.

KNIGHT-KITS ARE THE FIRST CHOICE OF EXACTING BUILDERS OF ELECTRONIC KITS EVERYWHERE AND HAVE BEEN SINCE THE EARLY 20's. THERE IS AN OUTSTANDING KNIGHT-KIT AVAILABLE FOR EVERY REQUIREMENT. EACH IS A REWARDING ADVENTURE IN KIT CONSTRUCTION. YOU WILL BE PROUD TO BUILD AND OWN A KNIGHT-KIT.

K4XL's **BAMA**

This manual is provided **FREE OF CHARGE** from the "BoatAnchor Manual Archive" as a service to the Boatanchor community.

It was uploaded by someone who wanted to help you repair and maintain your equipment.

If you paid anyone other than BAMA for this manual, you paid someone who is making a profit from the free labor of others without asking their permission.

You may pass on copies of this manual to anyone who needs it. But do it without charge.

Thousands of files are available without charge from BAMA. Visit us at <http://bama.sbc.edu>